



G A N
D I A
B L A
S C O

Gandia Blasco Group



WHITE. WHITE BATYLINE®. WHITE POLYETHYLENE.

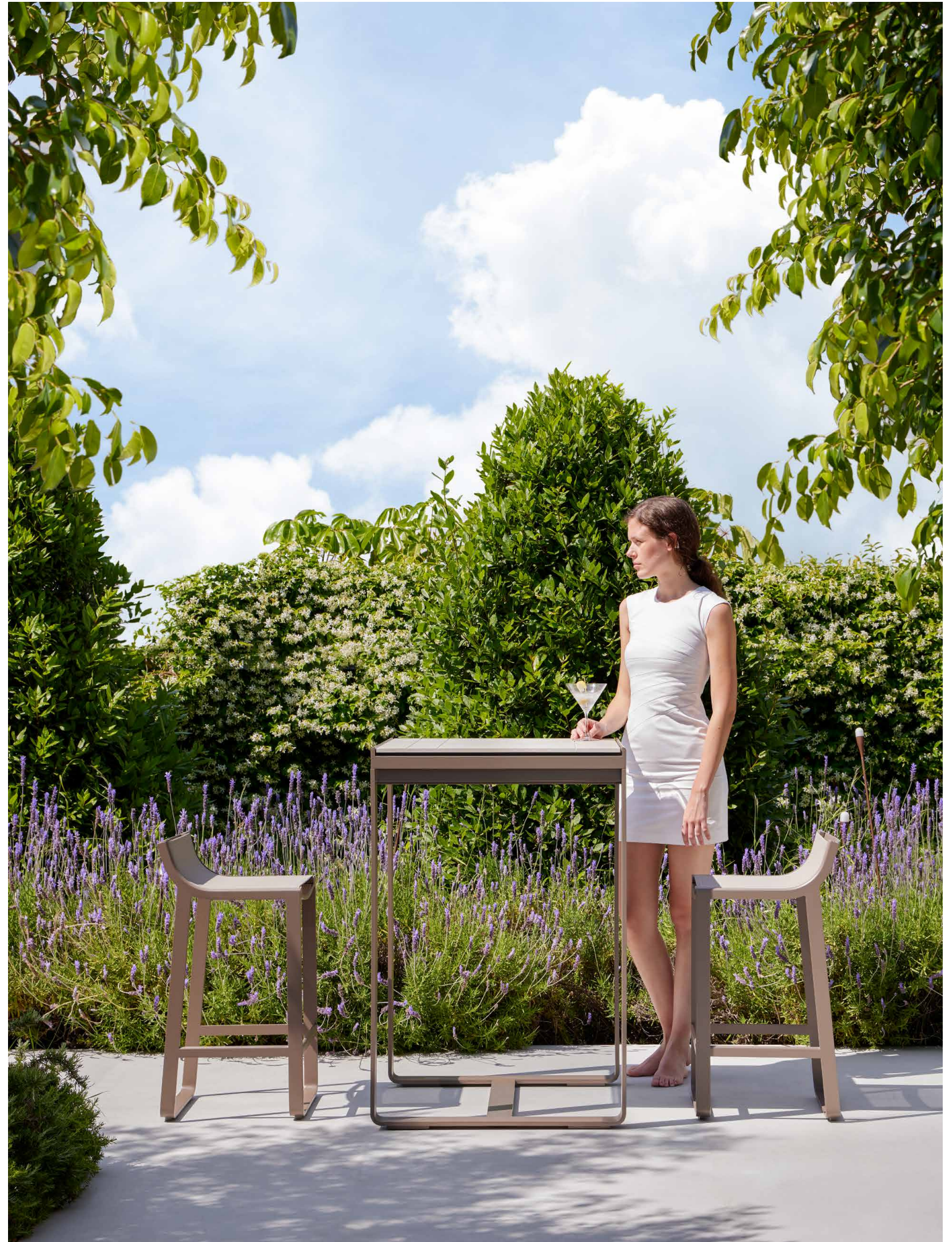

BRONZE. DANAE DEKTON®. STONE BATYLINE®.

GBMODULAR

by JOSÉ A.
GANDÍA-
BLASCO
CANALES





BLACK.

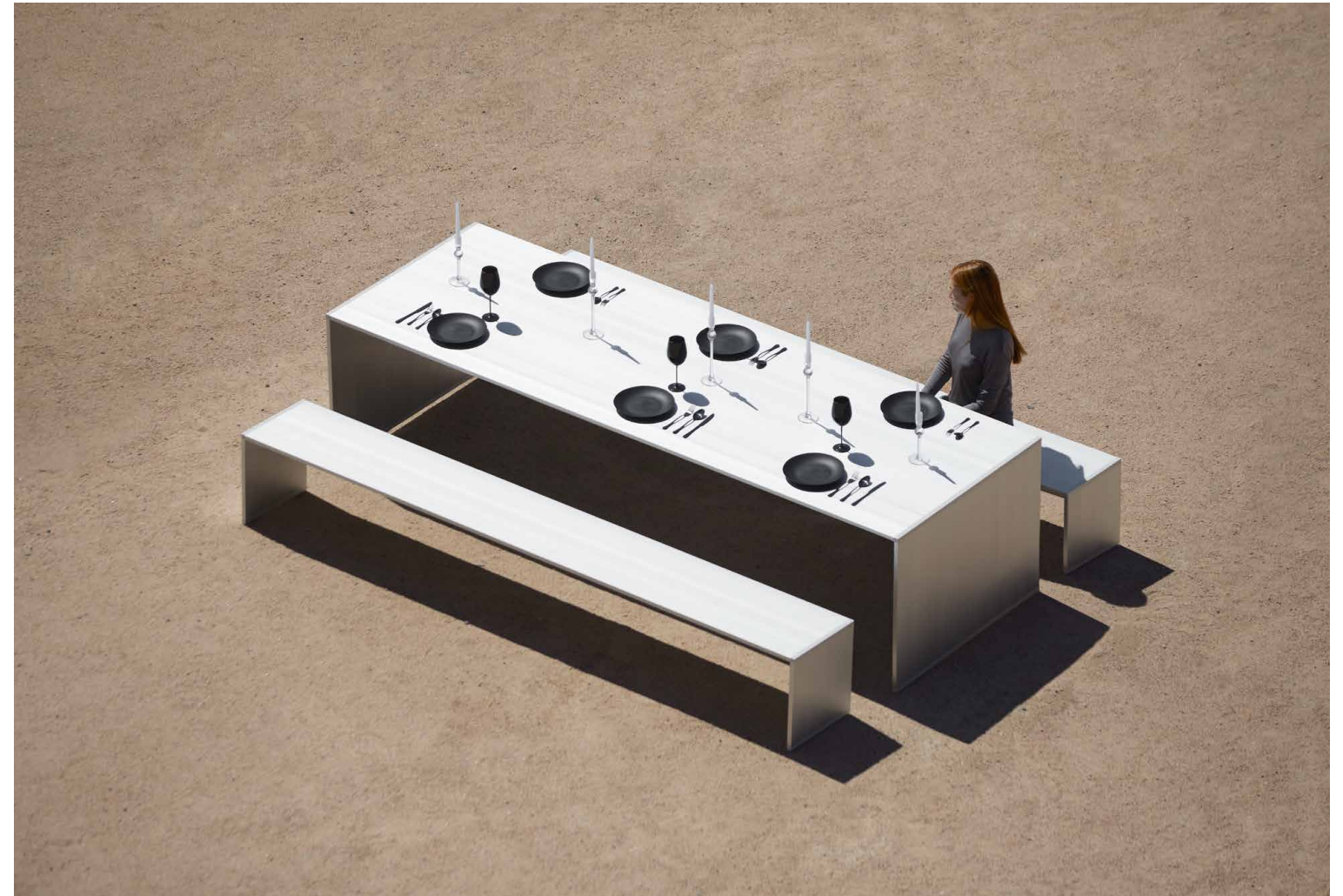

ANODIZED.

CAPA

BLACK. IROKO ARM. RADIUM DEKTON®. ATLAS PLAIN 98 MAT. DIAMOND ORANGE WINE RUG.

by
SØREN
ROSE





BLACK. BOTTLE GREEN. IROKO ARM. RADIUM DEKTON®. ATLAS PLAIN 98 MAT. DIAMOND ORANGE WINE RUG.



BOTTLE GREEN. IROKO ARM. DANAE DEKTON®. PATIO 230 MAT. DIAMOND GREEN GREY RUG.

“Sustainability has always been at the core of Søren Rose Studio. When we designed CAPA, we strived to create an original collection that, above all, will last for many years thanks to its quality and design. The full circle in sustainability occurs when manufacturer and designer share the same objective, as has been the case in this collaboration with GANDIABLASCO”.



“La sostenibilidad siempre ha sido el núcleo de Søren Rose Studio. Cuando diseñamos CAPA, nos esforzamos para crear una colección original pero que, sobre todo, perdurase durante muchos años gracias a su calidad y diseño. El círculo completo en sostenibilidad se da cuando fabricante y diseñador tienen el mismo objetivo, como ha sido el caso en esta colaboración con GANDIABLASCO”.

BUIT

by **MAYICE**
STUDIO

AGATE GREY AND GREY FABRIC.





BUIT responde a la esencia y ADN de GANDIABLASCO, el aluminio y el textil que llevan presentes desde sus orígenes en 1941. Es una malla metálica de aluminio ultraligera que podía ser una alfombra o, deformándose, un sofá, una tumbona, una mesa... desde el comienzo se pensó en que esa malla se entrelazara con textil generando un contraste entre materiales: lo frío del aluminio y lo cálido del textil. El trabajo con el textil también ha sido un proceso largo y una parte esencial de la colección gracias al desarrollo en I+D de Febrik by Kvadrat®.

BUIT outdoor furniture collection responds to the essence and DNA of GANDIABLASCO, the aluminium and the textile that have been present since its origins in 1941. Is an ultra-light aluminium wire mesh that could be a carpet or, deforming itself, a sofa, a deckchair, a table... from the beginning it was thought that this mesh would interweave with textile generating a contrast between materials: the cold of the aluminium and the warm of the textile. Working with textiles has also been a long process thanks to the exclusive R+D development by Febrik by Kvadrat®.

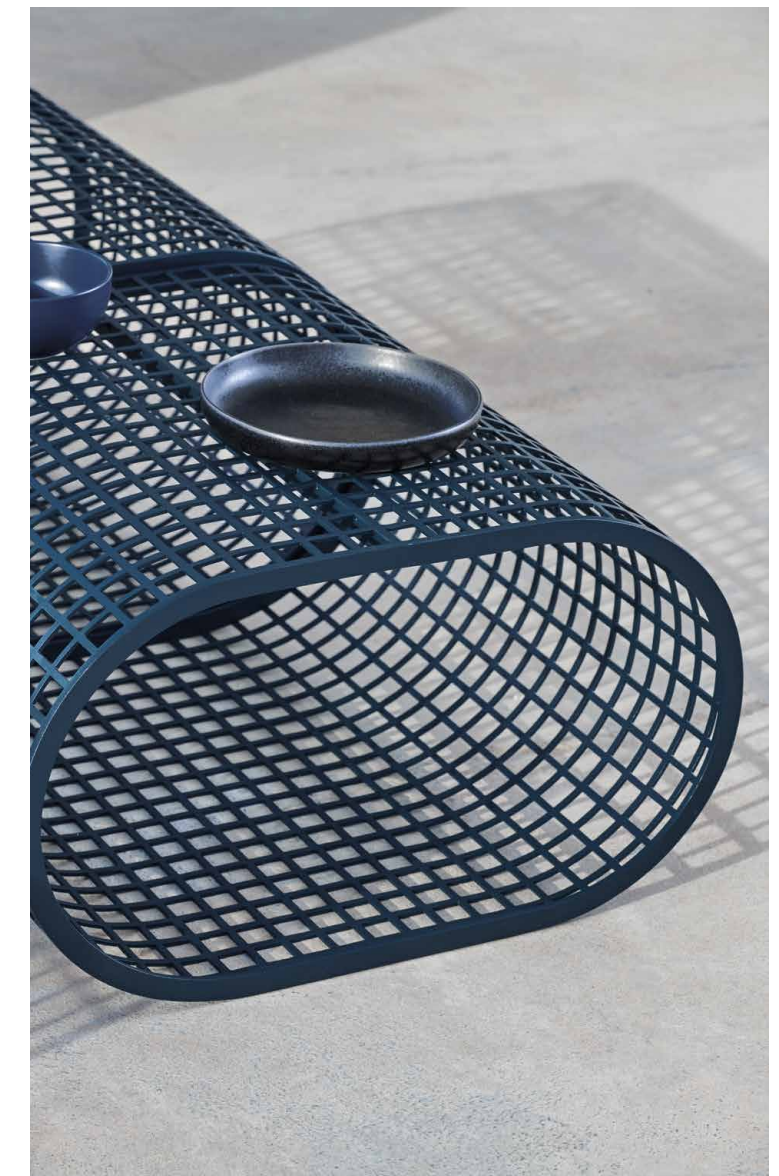

GREY BLUE. GREY BLUE AND GREY FABRIC.

BLAU

by FRAN
SILVESTRE

AGATE GREY.

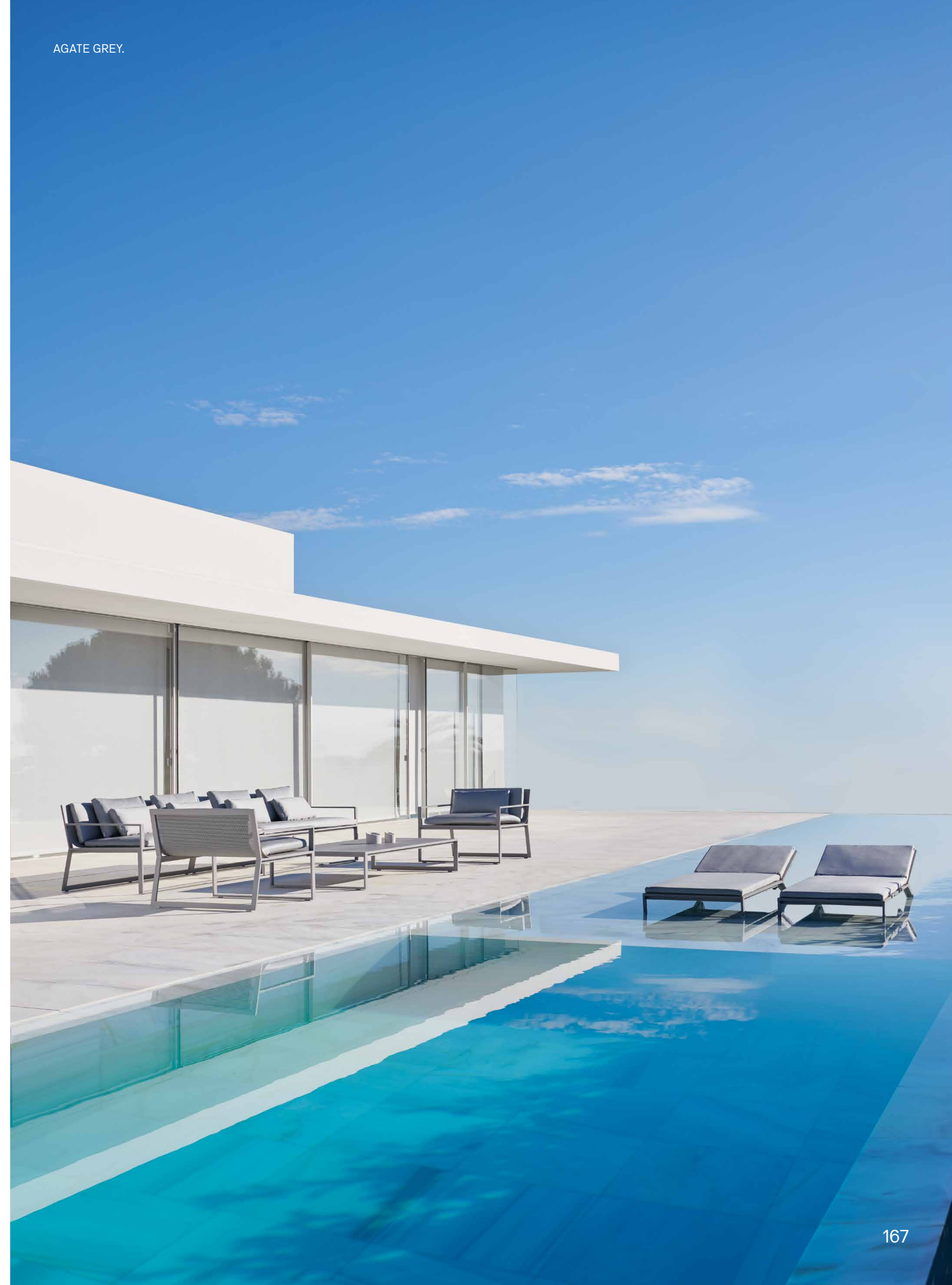

The BLAU collection seeks to develop the tradition of outdoor furniture, linking with the Mediterranean architecture and way of inhabiting.

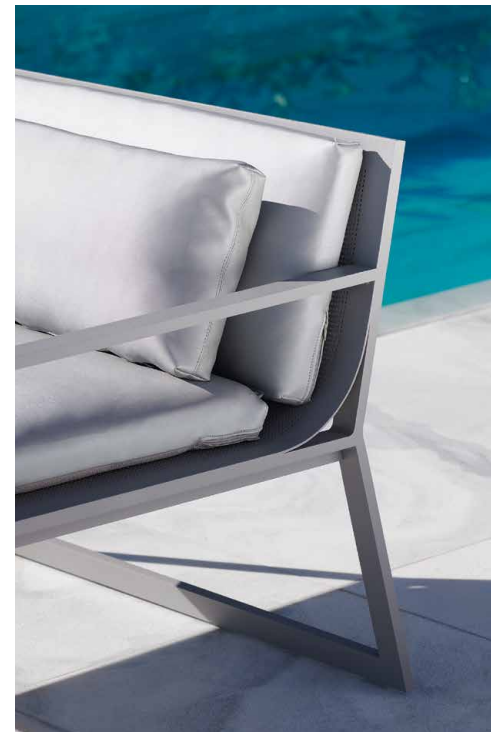

AGATE GREY. GEMINI ASHGREY MAT.

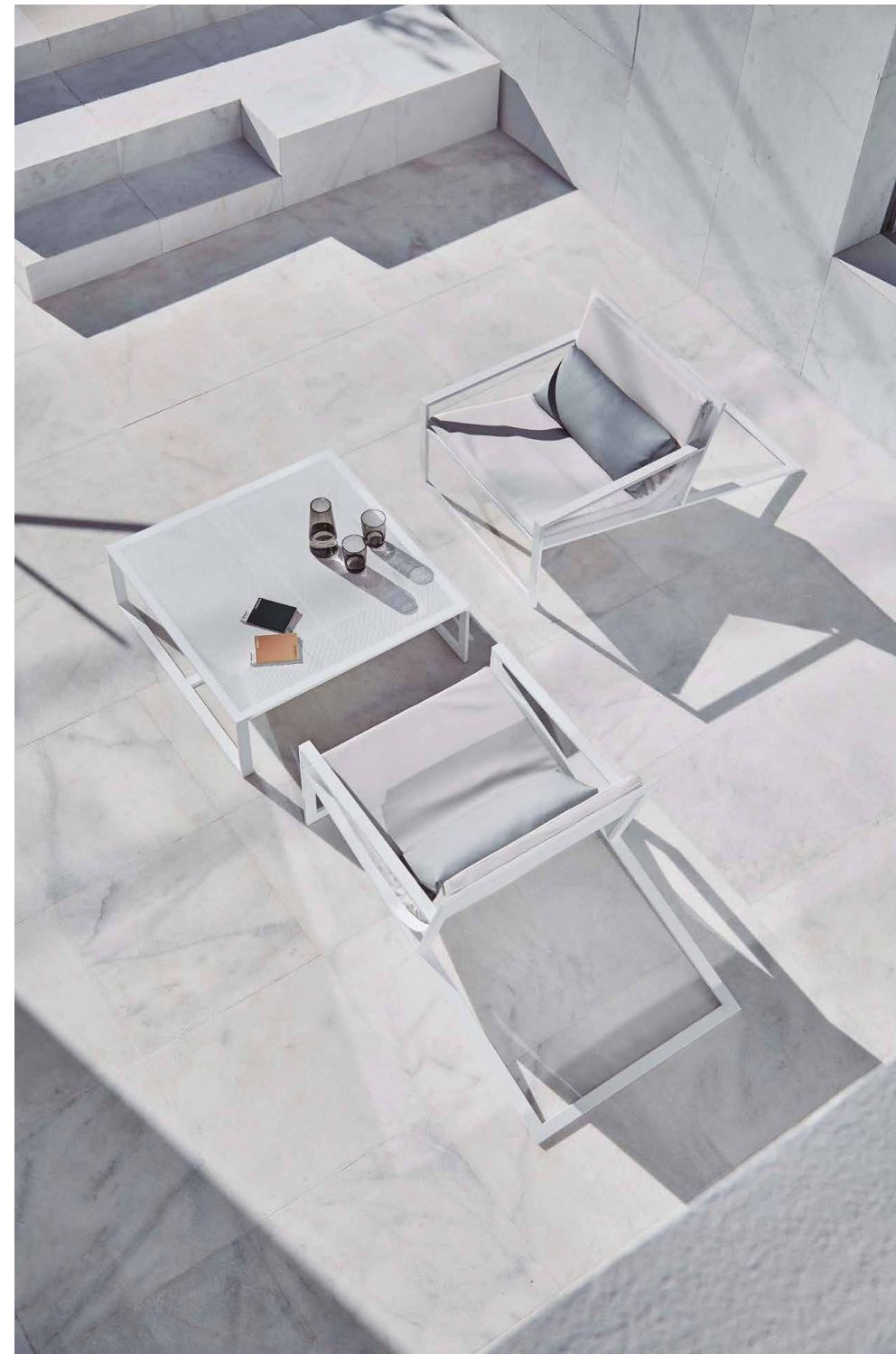

WHITE. SILVERTEX ICE MAT.

La colección BLAU busca desarrollar la tradición del mobiliario de exterior, vinculándose con la arquitectura y la forma de habitar del Mediterráneo.





AGATE GREY.

WHITE.



STACK

GREY BLUE. BLUE BATYLINE®.

by BORJA
GARCÍA



Inspired by the nautical world with design elements reminiscent of the 1960's and 1970's.



BLUE GREY. BLUE BATYLINE®. GARDEN LAYERS DIAGONAL ALMOND-BLUE. WHITE ENSOMBRA.



AGATE GREY. GREY BATYLINE®.

Inspirada en el mundo náutico y con reminiscencias estilísticas de los años 60-70.



QUARTZ GREY. BRONZE BATYLINE®.
ANTHRACITE PHENOLIC. DOLCE MARRON 09.

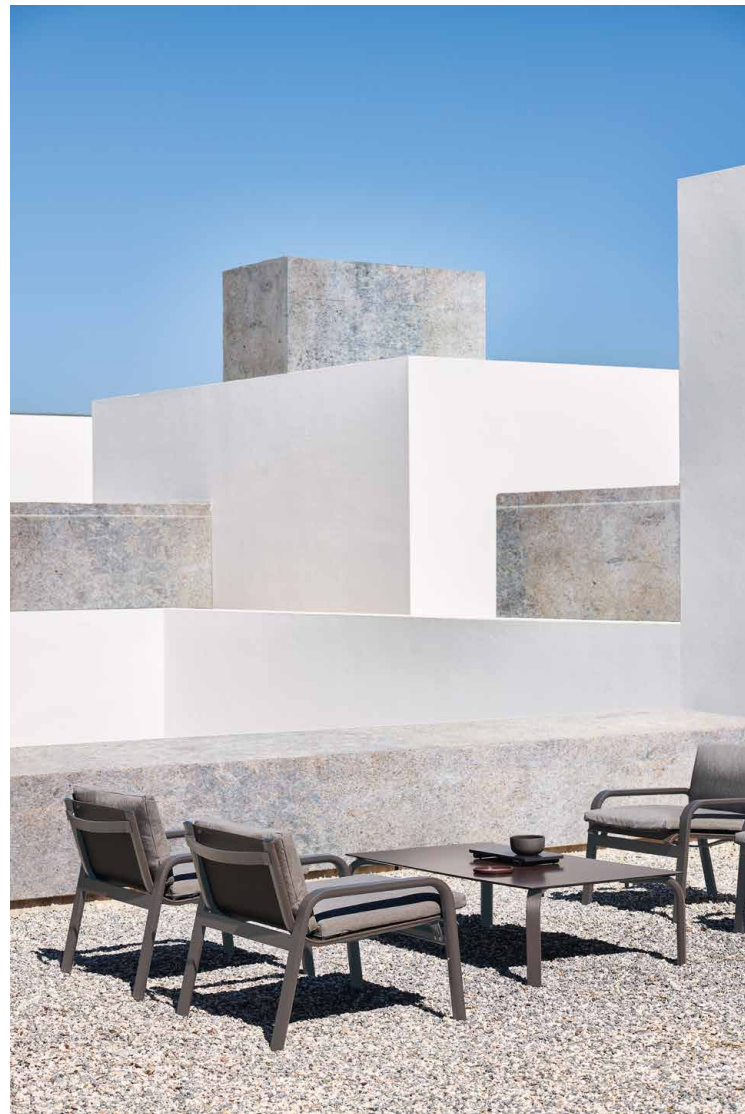

AGATE GREY. FOLKSTONE PHENOLIC. BOTTLE GREEN.

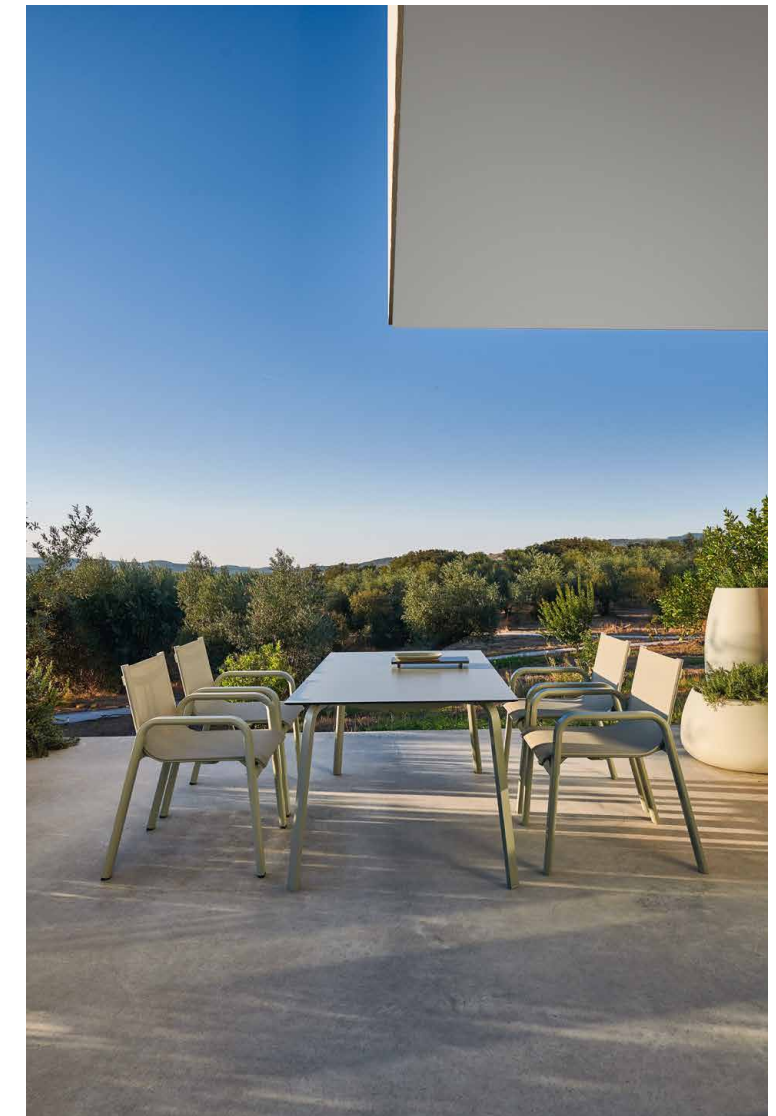

CEMENT GREY. GREEN BATYLINE®. POSSUM PHENOLIC.
AGATE GREY. GREY BATYLINE®.

The collection's clean and straightforward structures along with the materials used give shape to simple, balanced, and incredibly light pieces.

CEMENT GREY. GREEN BATYLINE®. POSSUM PHENOLIC.



La estructura clara y sincera configura unas piezas elementales, equilibradas y sumamente livianas gracias a los materiales y al concepto formal que rige toda la colección.

TEXTILE

by
ANA LLOBET

WHITE. NAVY ROPE.





QUARTZ GREY. AGATE GREY POLYETHYLENE. GREY ROPE.



BRONZE. BRONZE POLYETHYLENE AND PHENOLIC. BROWN ROPE.

“We devised our OUTDOOR SPACES as a concept closer to architecture than to furniture.” “GANDIABLASCO was a pioneer in creating aluminum PERGOLAS in a contemporary version.” “We are exploring new forms and technical functionalities to make PERGOLAS more sophisticated and complete spaces”.

José A. Gandía-Blasco Canales.

“Ideamos nuestros ESPACIOS DE EXTERIOR como un concepto más cercano a la arquitectura que al mobiliario.” “GANDIABLASCO fue pionera en crear PÉRGOLAS de aluminio en versión contemporánea.” “Estamos explorando nuevas formas y funcionalidades técnicas para hacer de las PÉRGOLAS espacios más sofisticados y completos”.

José A. Gandía-Blasco Canales.

OUTDOOR SPACES

PERGOLA

by JOSÉ A. GANDÍA-BLASCO CANALES

GREY BLUE. MINERAL CURTAINS. SAND TAU FLOOR.

“Feel the place and melt into it. Enjoy the outdoors in freedom but without giving up your privacy, to enjoy the outdoors whatever the season, has consolidated us not only in the design of modular and architectural spaces with a Mediterranean character, but also in the creation of complete environments capable of extending the passion for the outdoors to any place in the world, 365 days a year”.

“Sentir el lugar, fundirse en él, disfrutar del aire libre en libertad pero sin renunciar a la intimidad, sea cual sea la estación del año, nos ha llevado a diseñar espacios modulares y arquitectónicos con carácter mediterráneo, para transformar el espacio en una auténtica experiencia lodge bajo el sol, la lluvia, el viento o la nieve”.















SOFA PERGOLA

by JOSÉ A. GANDÍA-BLASCO CANALES

GREY BLUE. GEMINI BLANCO. ANTHRACITE SOLTIS.



DAYBED

by JOSÉ A. GANDÍA-BLASCO CANALES

BLUE GREY. GEMINI BLANCO. WIND WHITE.





WHITE. WHITE SOLTIS AND GEMINI.

DAYBED. CHILL by JOSÉ A. GANDÍA-BLASCO CANALES

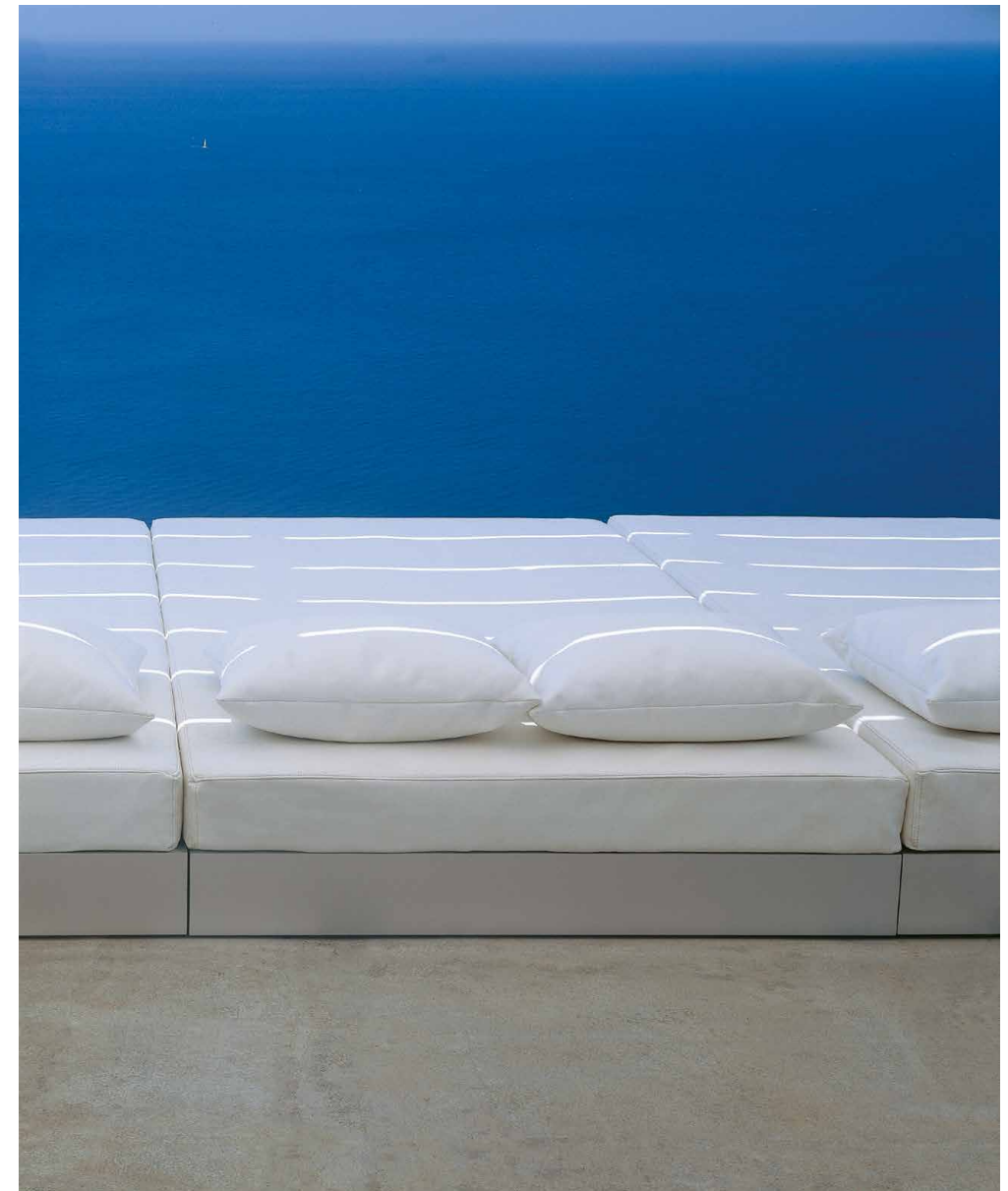

ANODIZED. WHITE GEMINI.

MERENDERO

by JOSÉ A. GANDÍA-BLASCO CANALES

GREY BLUE. BLUE GREY POLYETHYLENE. WHITE SOLTIS.



NAO-NAO

by YOLANDA HERRAIZ

GREY BLUE. GEMINI BLANCO. ANTHRACITE SOLTIS.



TIPI

by JOSÉ A. GANDÍA-BLASCO CANALES

WHITE. WHITE SOLTIS AND GEMINI.



AL FRESCO

by JOSÉ A. GANDÍA-BLASCO CANALES

QUARTZ GREY. BRONZE SOLTIS. GEMINI BLANCO.



Our collection of outdoor accessories includes a selection of objects and small pieces of furniture with a very special design that complete your outdoor experience. Candle box, planters, folding parasols, partition walls, deckchairs, objects capable of infusing a space with elegance, which also function as complements to the GANDIABLASCO furniture collections.

Nuestra colección de complementos de exterior comprende una selección de objetos y pequeños muebles con un diseño muy especial para completar tu experiencia al aire libre. Faroles, maceteros, sombrillas, celosías, hamacas, objetos capaces de dotar de elegancia al espacio, y que funcionan también como complementos de las colecciones de mobiliario GANDIABLASCO.

ACCESSORIES

UMBRA

by DIRK WYNANTS

WHITE. NATURAL FABRIC.



BALI

by ODOSDESIGN



BOTTLE GREEN. OLIVE OPAC.



ENSOMBRA

by ODOSDESIGN

Ensombra 17 years later. A GANDIABLASCO international icon. In 2006, the iconic parasol burst onto the outdoor design scene as an aesthetically pleasing version, pioneered by its fresh and innovative opening system. To this day, the emblematic umbrella has conquered private and contract outdoor spaces on all continents.

Ensombra 17 años después. Icono internacional de GANDIABLASCO. En 2006, el icónico parasol irrumpió en la escena del diseño para exteriores como una versión de atractiva estética, pionera por su fresco y novedoso sistema de apertura. A día de hoy, la emblemática sombrilla ha conquistado espacios outdoor privados y contract en los cinco continentes.

ANTHRACITE.



CELOSÍAS

by JOSÉ A. GANDÍA-BLASCO CANALES

WHITE. DNA FAUX WOOD ALUMINIUM TK001 AND RB001. BLACK AND SILVER SOLTIS.



PICNIC

by JOSÉ A. GANDÍA-BLASCO CANALES



AGATE GREY. STRANGE LOVES SEA ANCHOR TEXTILE.



CLACK!

by JOSÉ A. GANDÍA-BLASCO CANALES



CLACK! is an improved version of the traditional wood and canvas folding beach chair, but its structure isn't wood, it's aluminum. This changes everything, making it lighter and more weather resistant, but more stylish too. That's why it fits equally well into an informal beach setting as in an elegant outdoor dining area.

CLACK! es una revisión en aluminio de la tradicional silla plegable de playa de madera y lona, pero más ligera y resistente a la intemperie. Por eso encaja igual de bien a la orilla del mar, que en un elegante comedor de exterior.

BLACK. LIGHT GREY BATYLINE®. BLACK PHENOLIC.



GRAPY

by KENSAKU OSHIRO



GRAPY is an outdoor seat inspired by the jute bags on which farmers used to rest during their long days of outdoor work. Nature itself lends it its flexibility and its relaxing qualities. Exhaustively studied ergonomics give this piece the ability to adapt smoothly to the movements of your body.

GRAPY es un asiento de exterior inspirado en los sacos de yute que los agricultores empleaban para descansar durante sus largas jornadas de trabajo al aire libre. La misma naturaleza le presta su flexibilidad y la capacidad de ofrecer el mayor relax. La ergonomía, estudiada exhaustivamente, confiere a este volumen la capacidad de adaptarse con suavidad al movimiento de tu cuerpo.



SAIL
by HÉCTOR SERRANO



SILVERTEX JET MAT.

ARAM
by NENDO



WHITE AND GREY BLUE.

SAHARA
by PABLO GIRONÉS



WHITE. BLUE GREY.

SONORA
by PABLO GIRONÉS



SAND. CEMENT GREY. BOTTLE GREEN.

FEZ
by JOSÉ A. GANDÍA-BLASCO CANALES



WHITE.

LLAR
by BORJA GARCÍA



BLACK AND WHITE.

LA SIESTA

by RAKY MARTÍNEZ, ALBERTO MARTÍNEZ Y HÉCTOR SERRANO



“We invite you to take a sip Mediterranean style”.

“Os invitamos a echar un trago al más puro estilo mediterráneo”.

WHITE. COBALT BLUE.



75 countries on 5 continents. From the Mediterranean coast to the Atlantic coast, from the cradle of the Mediterranean to the European bohemia of France, crossing the Atlantic from Asia to neuralgic New York, we get to the houses belonging to persons and cultures from all over the world.

The search for essential elegance leads GANDIABLASCO to collaborate on creative projects that understand contemporary beauty from a shared perspective.

Luxury brands such as Dom Pérignon, fully confide in the quality of the GANDIABLASCO outdoor furniture collections for their unique creative.

75 Países 5 continentes.
De la Costa del Mediterráneo a la Costa del Atlántico, de la cuna del Mediterráneo a la Francia de la bohème europea, cruzando el Atlántico desde Asia hasta la neurálgica Nueva York, llegamos a las casas de personas y culturas de todo el mundo.

La búsqueda de una elegancia esencial hace que GANDIABLASCO colabore en proyectos residenciales y de contract que entienden la belleza contemporánea de esta misma manera.

Casas privadas, hoteles y restaurantes de todo el mundo, yates y marcas de lujo como Dom Pérignon, confían en la calidad de los muebles y espacios de exterior de GANDIABLASCO para recrear sus singulares experiencias al aire libre.

PROJECTS



FIELD HOUSE. LONG ISLAND. NEW YORK.



LH BANGKOK THONGLOR. BANGKOK. THAILAND.



CARLA RIDGE. BEVERLY HILLS. LOS ANGELES. USA



EAGLES NEST. BAY OF ISLANDS. NEW ZEALAND.



AKA TERRACE. CENTRAL PARK. NEW YORK. USA.

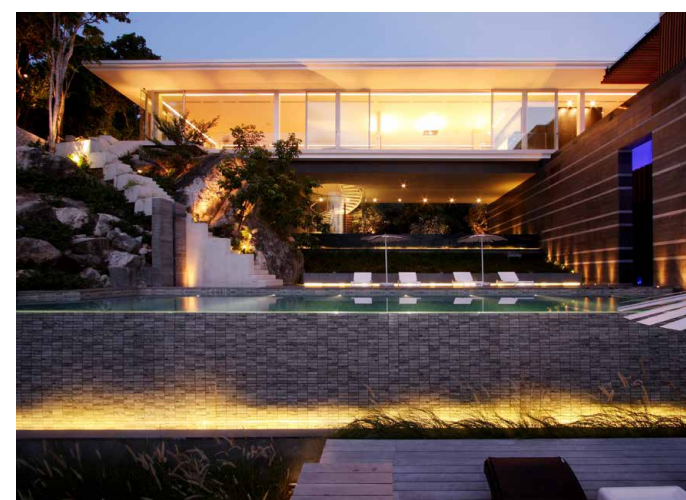

VILLA MAYAVEE. PHUKET. THAILAND.

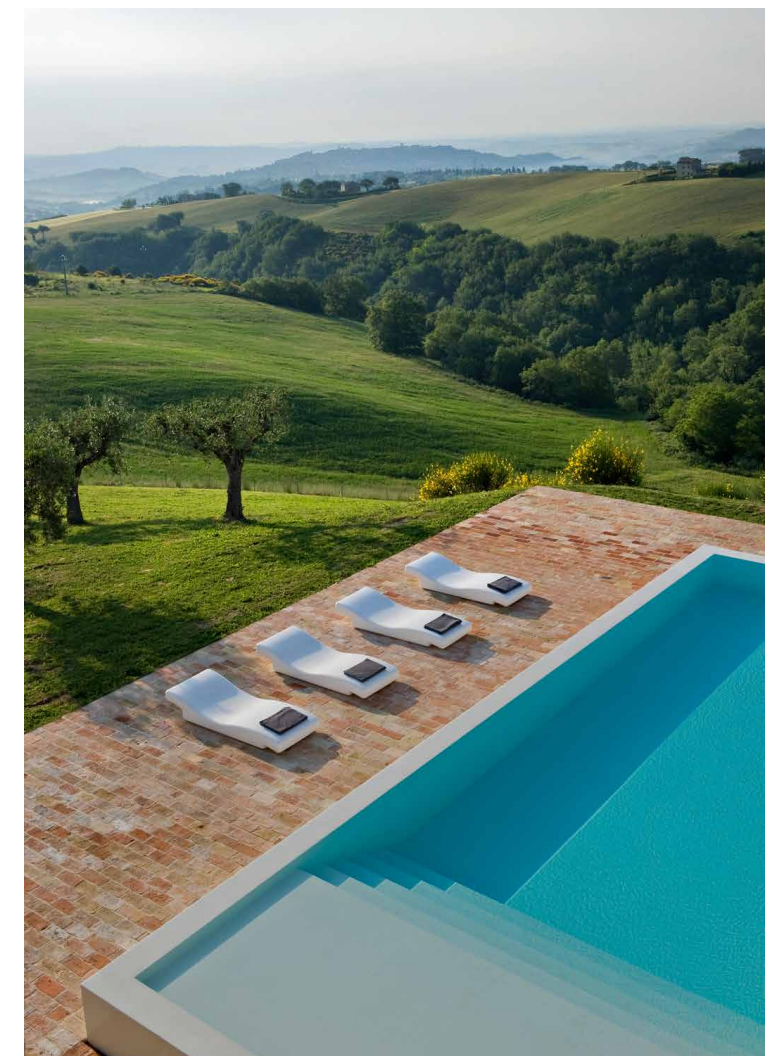

CASA OLIVI. LE MARCHE. ITALY.

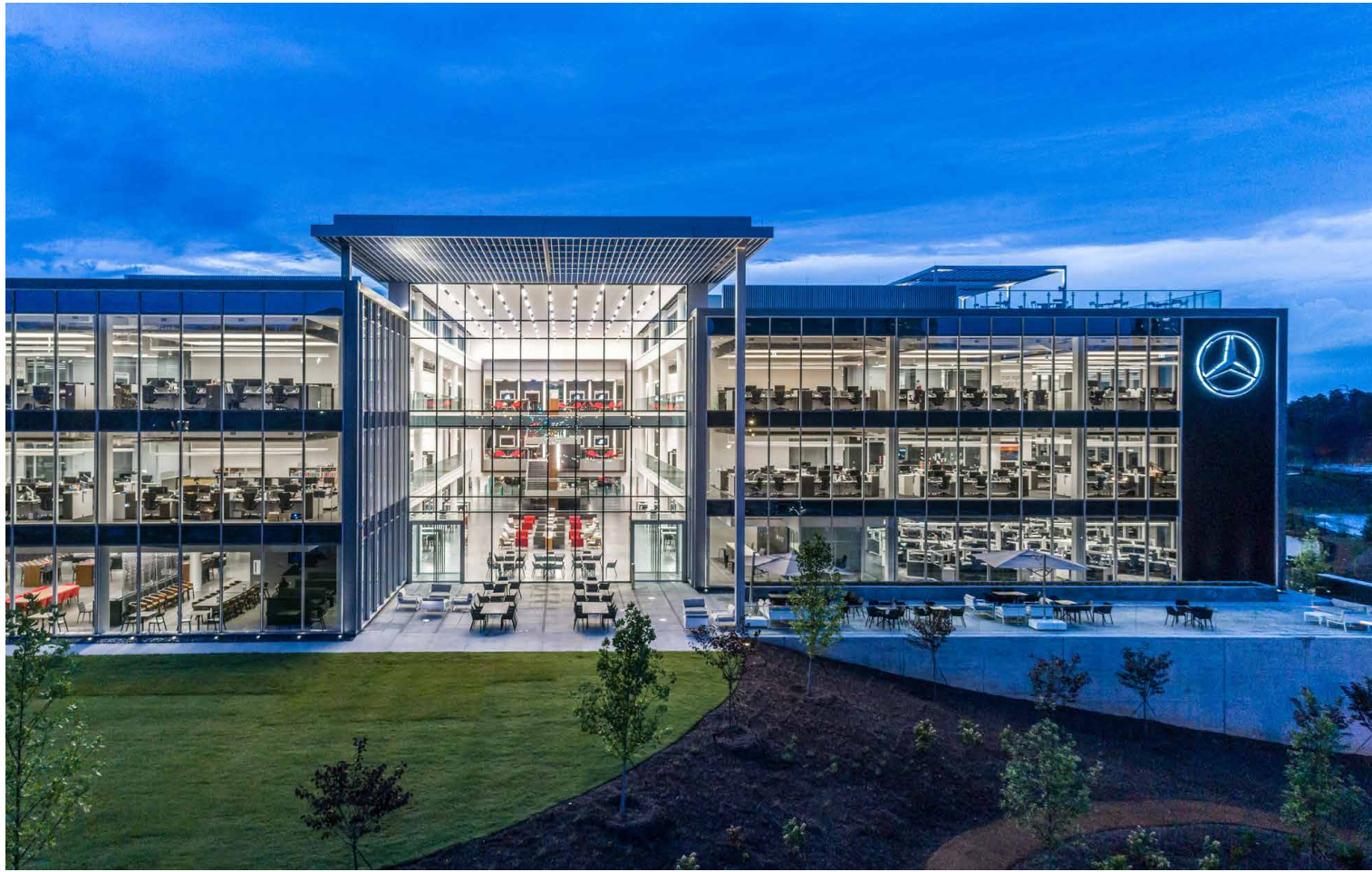

MERCEDES BENZ OFFICES. GENSLER. ATLANTA.



MERCEDES BENZ OFFICES. GENSLER. ATLANTA.



ROCKEFELLER & CO. NUEVA YORK. NY.



HOTEL W. BARCELONA. SPAIN.



HOTEL OMM. BARCELONA. SPAIN.

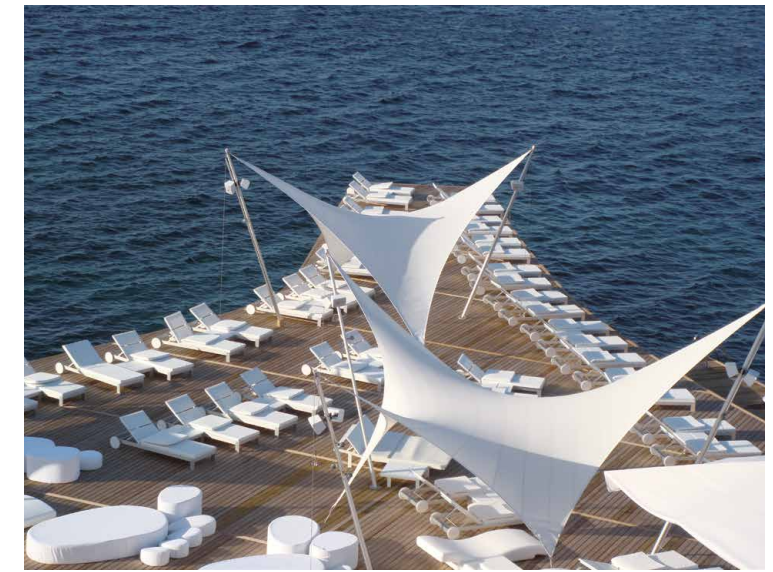

HOTEL KUUM. BODRUM. TURKEY.



HOTEL MARINA BAY. SINGAPORE.

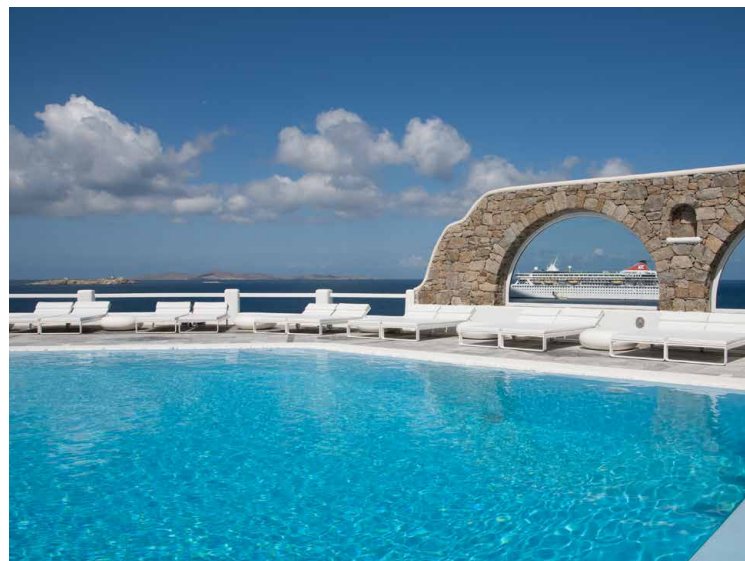

HOTEL KOUROS. MYKONOS. GREECE.



HOTEL LE VIEUX. CASTILLON DU GARD. FRANCE.



HOTEL MARIS. MARMARIS. TURKEY.



HOTEL THE RITZ CARLTON BAHRAIN & SPA. MANAMA. KINGDOM OF BAHRAIN.



BALNEARIO VICHY CATALAN. CALDES DE MALAVELLA. SPAIN.

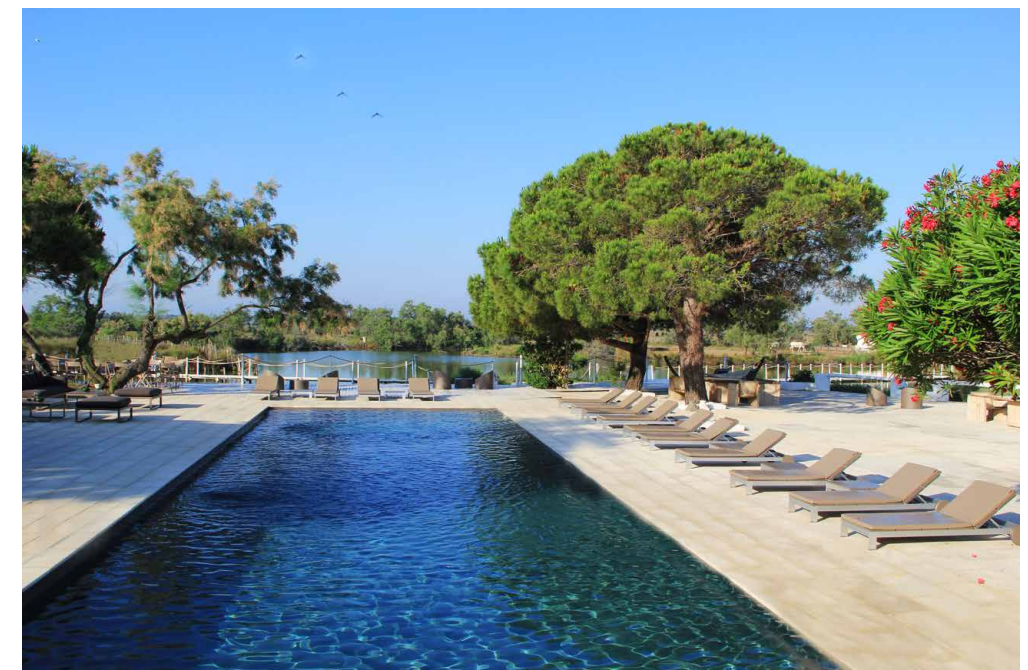

MAS DE LA FOUQUE. FRANCIA.

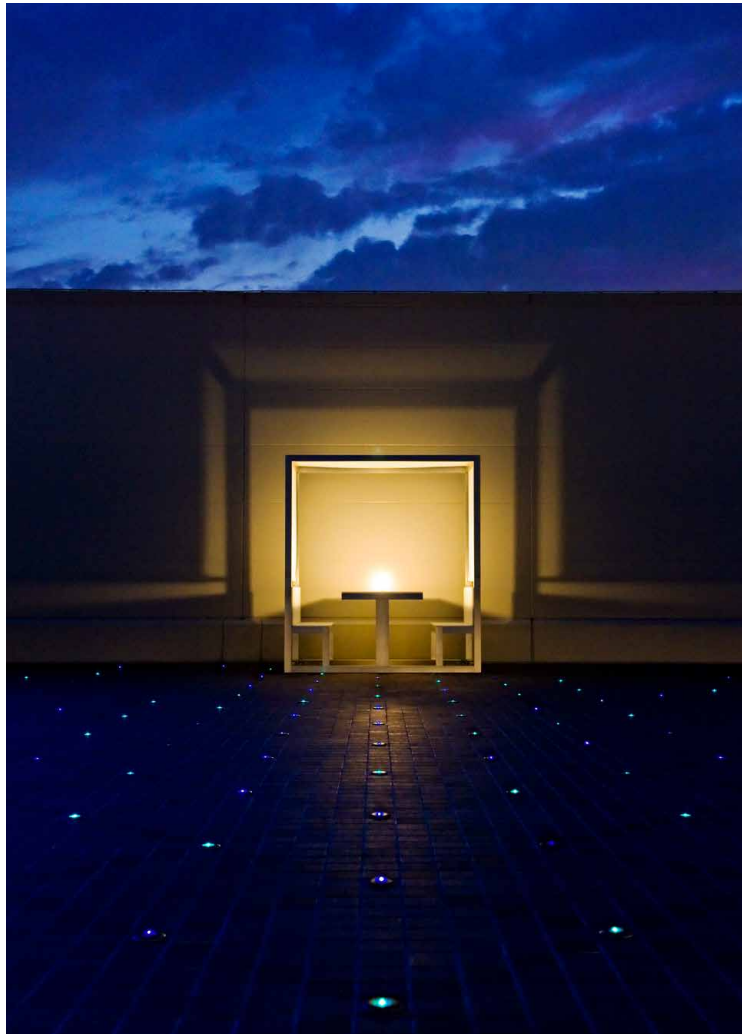

AIRPORT HANEDA. TOKIO. JAPAN.

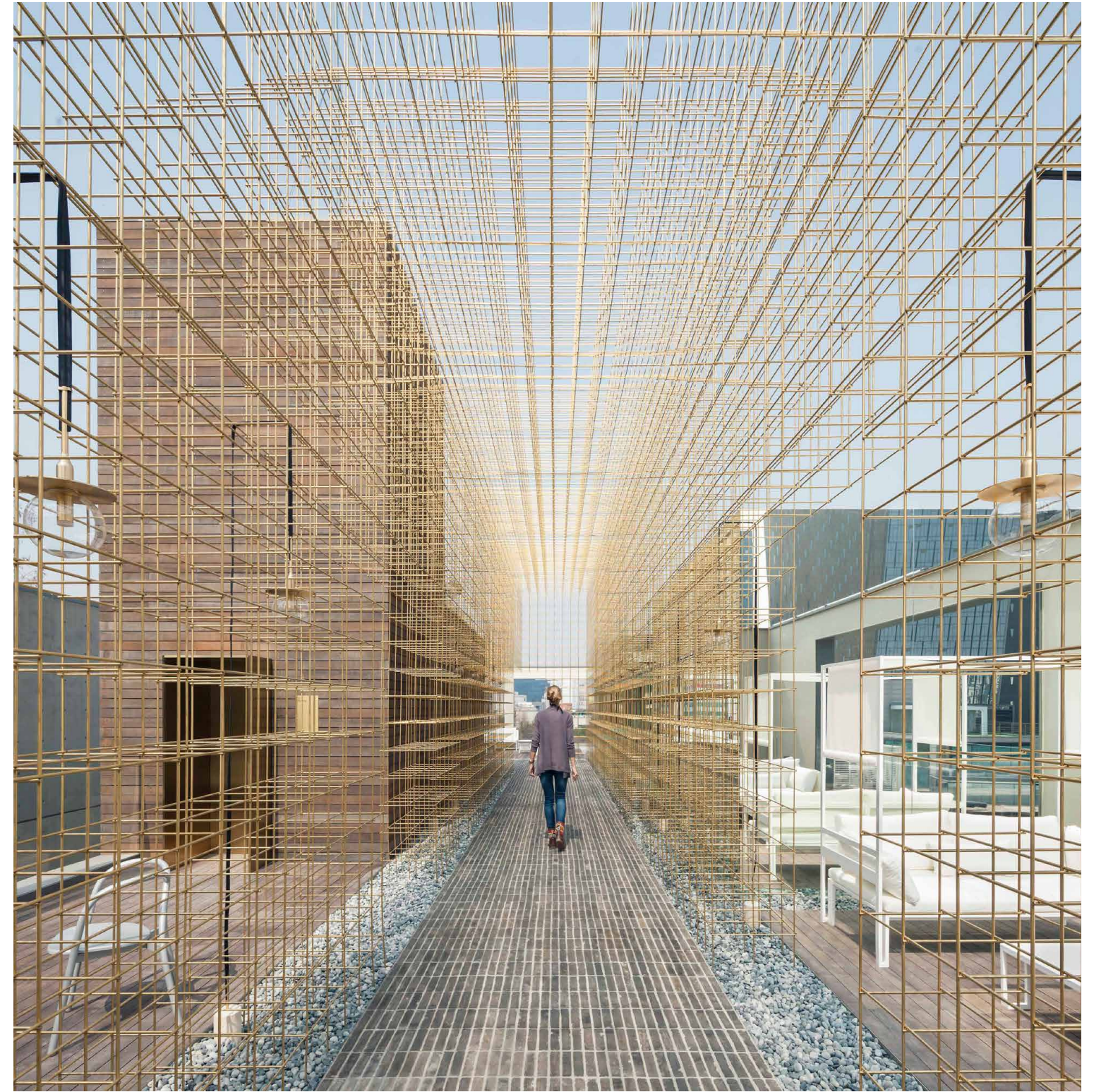
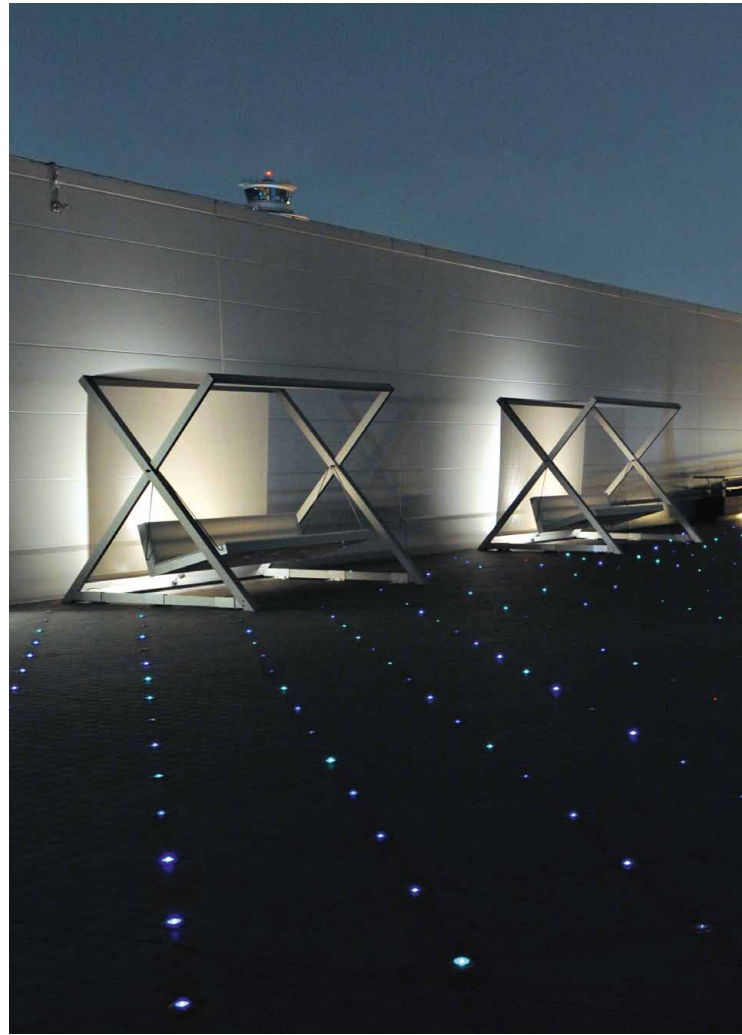

SULWHASOO FLAGSHIP STORE. SOUTH KOREA. NERI&HU.



AZALEA CRUISE. THE MALDIVES.





UTERQUE. IBIZA.



DOM PÉRIGNON.

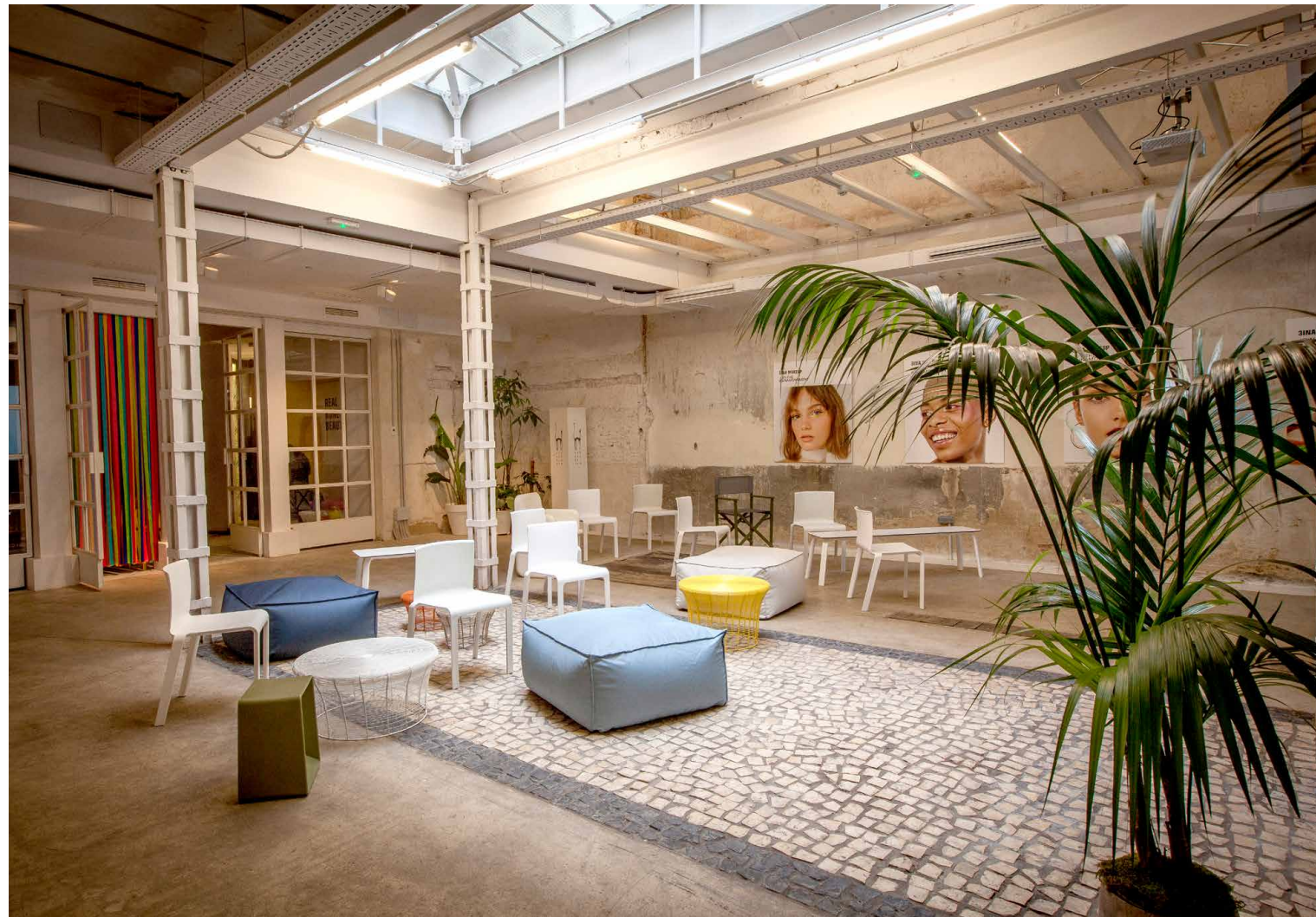

COSMÉTICOS 3INA.



SHOWROOM HUGO BOSS. ITALY.

TECHNICAL

GANDIABLASCO

NEWS	380
COLLECTIONS	383
OUTDOOR SPACES	402
ACCESSORIES	404
FABRICS COLLECTION	406
MATERIALS	408

TECHNICAL

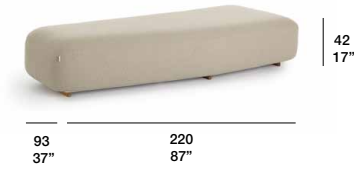

SOFA SEAT 01 / ASIENTO 01



SOFA SEAT 02 / ASIENTO 02

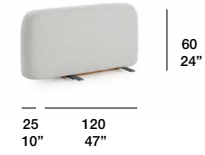

BACKREST 01 / RESPALDO 01

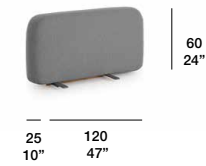

BACKREST 02 / RESPALDO 02

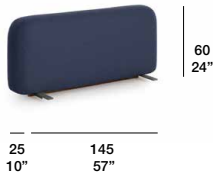

BACKREST 03 / RESPALDO 03

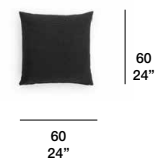

CUSHION / COJÍN

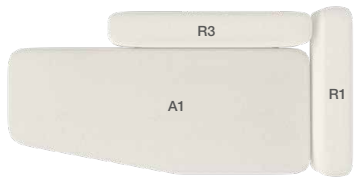

TYPLOGIES / TIPOLOGÍAS

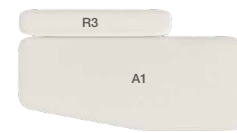

BACKREST JOINTS / UNIONES RESPALDO

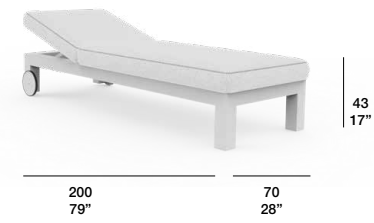

CHAISE LOUNGE / TUMBONA

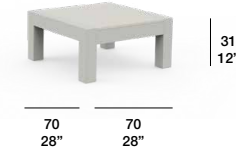

SIDE TABLE / MESA TUMBONA



LOUNGE CHAIR / SILLÓN



2 SEAT SOFA / SOFÁ 2 PLAZAS



SECTIONAL 1 / MODULAR 1

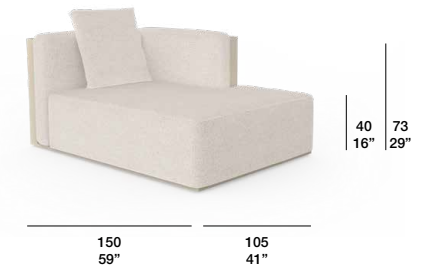

SECTIONAL 2 / MODULAR 2

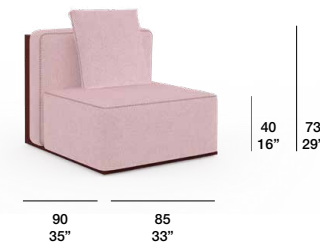

SECTIONAL 3 / MODULAR 3



SECTIONAL 4 / MODULAR 4

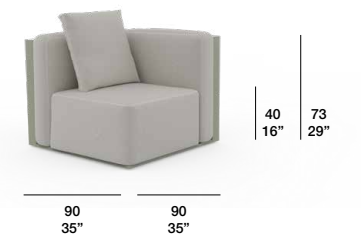

SECTIONAL 6 / MODULAR 6

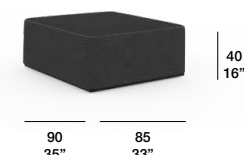

SECTIONAL POUF / PUF MODULAR

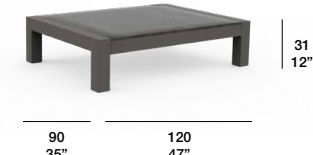

COFFEE TABLE / MESA BAJA



AROSA MODULE / MÓDULO AROSA



GOMERA MODULE / MÓDULO GOMERA



MENORCA MODULE / MÓDULO MENORCA

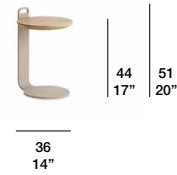

COFFEE TABLE / MESA BAJA

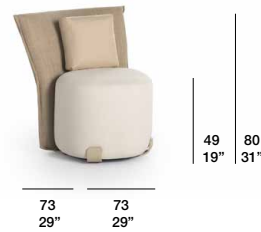
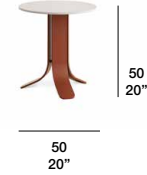

DINING CHAIR / SILLA



POUF / PUF

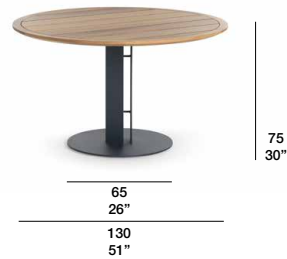

DINING TABLE / MESA ALTA

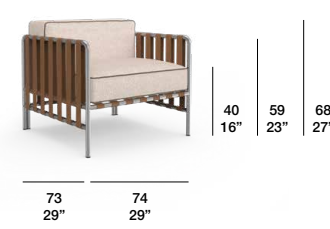
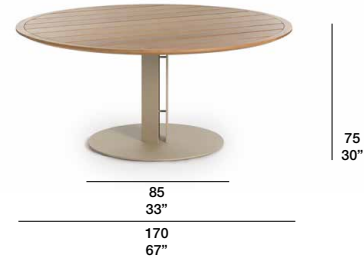
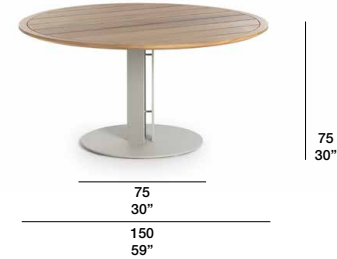

CLUB CHAIR / BUTACA

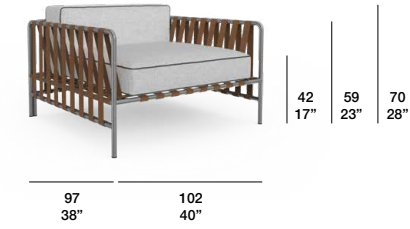

LOUNGE CHAIR / SILLÓN



2 SEAT SOFA / SOFÁ 2 PLAZAS



SECTIONAL 1 / MODULAR 1

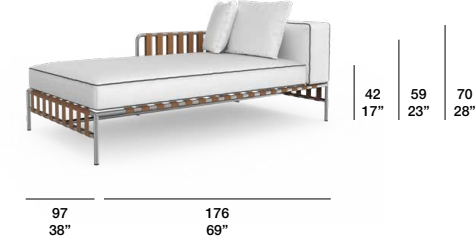

SECTIONAL 2 / MODULAR 2

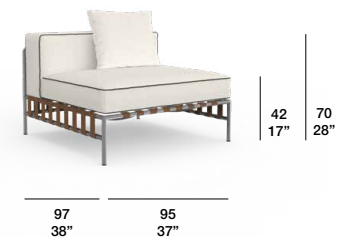

SECTIONAL 3 / MODULAR 3



SECTIONAL 4 / MODULAR 4



SECTIONAL 6 / MODULAR 6

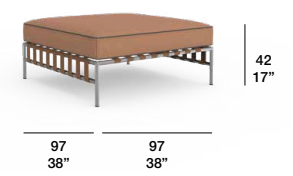

SECTIONAL POUF / PUF MODULAR

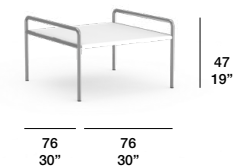

COFFEE TABLE / MESA BAJA

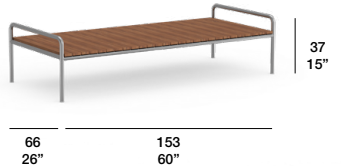
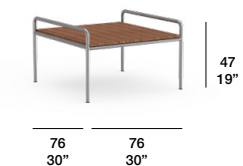
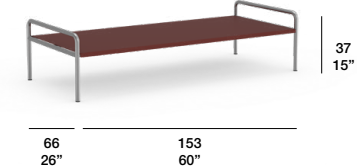

Iroko table / Mesa iroko

Iroko table / Mesa iroko

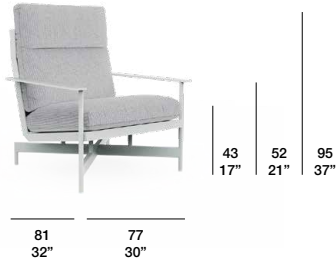

CLUB ARMCHAIR / BUTACA



CLUB ARMCHAIR POUF / PUF BUTACA



2 SEAT SOFA / SOFÁ 2 PLAZAS

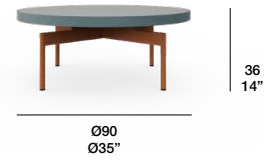

ROUND COFFEE TABLE / MESA BAJA CIRCULAR

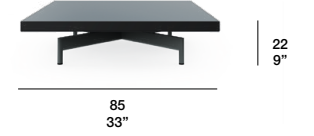

COFFEE TABLE / MESA BAJA



3 SEAT SOFA / SOFÁ 3 PLAZAS



LOUNGE CHAIR / SILLÓN



SECTIONAL 1 / MODULAR 1

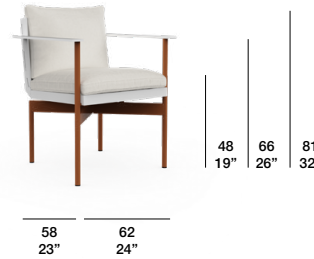

DINING ARMCHAIR / SILLA



DINING TABLE / MESA ALTA



SECTIONAL 2 / MODULAR 2



SECTIONAL 3 / MODULAR 3



SECTIONAL 4 / MODULAR 4



SECTIONAL POUF / PUF MODULAR

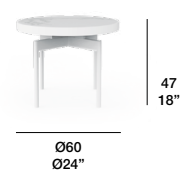

ROUND COFFEE TABLE / MESA BAJA CIRCULAR

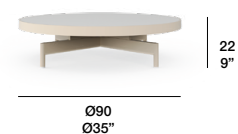



200
79" 80
31"

CHAISE LOUNGE / TUMBONA



82
32" 90
35" 45
18" 105
41" 146
57"

COCOON LOUNGE CHAIR / SILLÓN COCOON



Ø 175
Ø 69" 45
18" 67
26" 82
32"

ROUND CHILL BED / CAMA CHILL REDONDA



82
32" 180
71" 45
18" 82
32"

SECTIONAL 4 / MODULAR 4



82
32" 82
32" 45
18" 82
32"

SECTIONAL 6 / MODULAR 6



82
32" 90
35" 45
18"

SECTIONAL POUF / PUF MODULAR



135
53" 87
34" 45
18" 67
26" 82
32"

TU&YO SOFA / SOFÁ TU&YO



82
32" 90
35" 45
18" 67
26" 82
32"

LOUNGE CHAIR / SILLÓN



60
24" 82
32" 45
18"

POUF / PUF SILLÓN



45
18" 45
18" 35
14"

COFFEE TABLE / MESA BAJA



70
28" 70
28" 35
14"

COFFEE TABLE / MESA BAJA



90
35" 90
35" 35
14"

COFFEE TABLE / MESA BAJA



82
32" 180
71" 45
18" 82
32"

2 SEAT SOFA / SOFÁ 2 PLAZAS



82
32" 240
94" 45
18" 82
32"

3 SEAT SOFA / SOFÁ 3 PLAZAS



82
32" 180
71" 45
18" 82
32"

SECTIONAL 1 / MODULAR 1



90
35" 120
47" 35
14"

COFFEE TABLE / MESA BAJA



90
35" 150
59" 35
14"

COFFEE TABLE / MESA BAJA



Ø60
Ø24" 45
18"

COFFEE TABLE / MESA BAJA



180
71" 82
32" 45
18" 82
32"

SECTIONAL 2 / MODULAR 2



160
63" 140
55" 45
18" 82
32"

XL SECTIONAL 2 / MODULAR 2 XL



82
32" 90
35" 45
18" 82
32"

SECTIONAL 3 / MODULAR 3

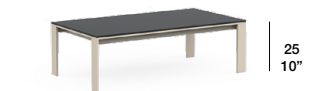

45
18" 82
32" 25
10"

SIDE TABLE / MESA AUXILIAR



60
23" 82
32" 25
10"

SIDE TABLE / MESA AUXILIAR

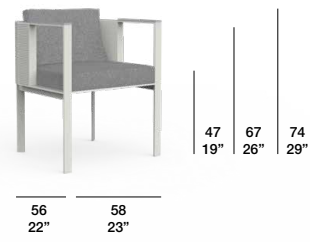

DINING ARMCHAIR / SILLA

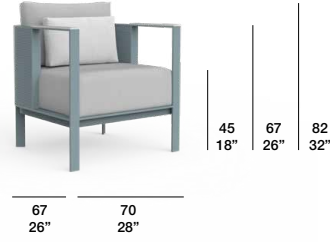

CLUB ARMCHAIR / BUTACA



CLUB ARMCHAIR TABLE / MESA BUTACA



DINING TABLE / MESA ALTA

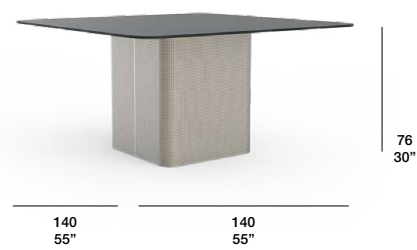

DINING TABLE / MESA ALTA



DINING TABLE / MESA ALTA

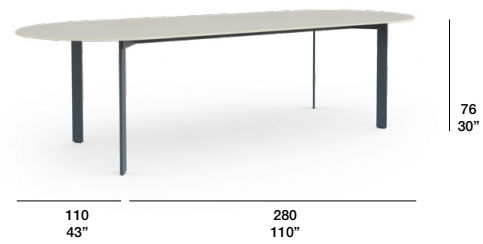

DINING TABLE / MESA ALTA

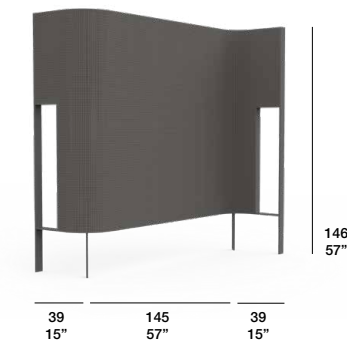

PARTITION WALL / CELOSÍA

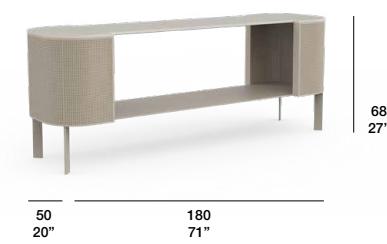

SIDEBOARD / APARADOR

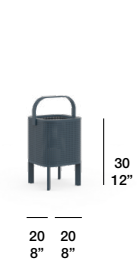

CANDLE BOX / FAROL

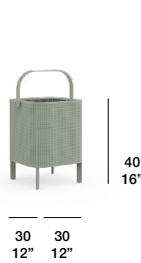

CANDLE BOX / FAROL



CANDLE BOX / FAROL

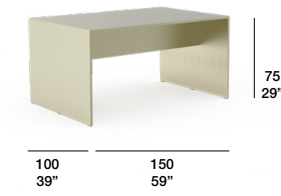

DINING TABLE / MESA ALTA



DINING TABLE / MESA ALTA

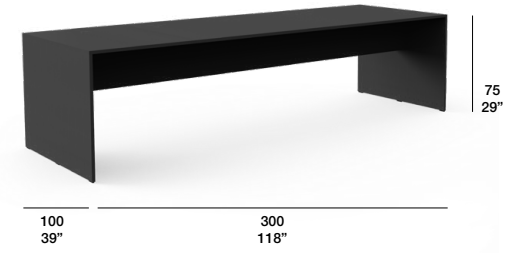

DINING TABLE / MESA ALTA

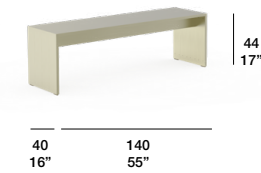

BENCH / BANCO



BENCH / BANCO

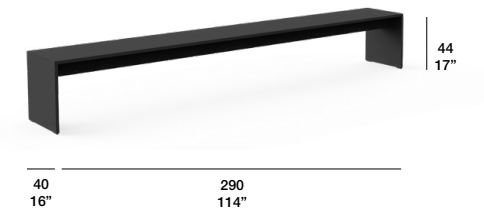

BENCH / BANCO



198 78" 70 28" 45 18"

CHAISE LOUNGE / TUMBONA



198 78" 170 67" 31 12" 45 18"

TWIN DOUBLE CHILL BED / CAMA CHILL DOBLE TWIN



198 78" 100 39" 45 18"

CAMA CHILL / CHILL BED

Chill bed 100 - 140 - 200 / Cama Chill 100 - 140 - 200



88 35" 180 71" 45 18" 67 26"

SECTIONAL 1 / MODULAR 1



90 35" 178 70" 45 18" 77 30"

SECTIONAL 2 / MODULAR 2



140 55" 163 64" 45 18" 67 26"

XL SECTIONAL 2 / MODULAR 2 XL

High backrest / Respaldo alto
Low backrest / Respaldo bajo

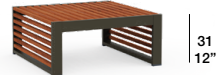

71 28" 70 28" 31 12"

SIDE TABLE / MESA TUMBONA



88 35" 105 41" 45 18" 67 26"

LOUNGE CHAIR / SILLÓN

High backrest / Respaldo alto
Low backrest / Respaldo bajo



88 35" 105 41" 45 18" 107 42"

NORMANDO LOUNGE CHAIR / SILLÓN NORMANDO

High backrest / Respaldo alto
Low backrest / Respaldo bajo



88 35" 90 35" 45 18" 77 30"

SECTIONAL 3 / MODULAR 3

High backrest / Respaldo alto
Low backrest / Respaldo bajo



88 35" 180 71" 45 18" 77 30"

SECTIONAL 4 / MODULAR 4

High backrest / Respaldo alto
Low backrest / Respaldo bajo



88 35" 88 35" 45 18" 67 26"

SECTIONAL 6 / MODULAR 6

High backrest / Respaldo alto
Low backrest / Respaldo bajo



88 35" 210 83" 45 18" 77 30" 187 74"

AL FRESCO SOFA / SOFÁ AL FRESCO

High backrest / Respaldo alto
Low backrest / Respaldo bajo



88 35" 150 59" 45 18" 67 26"

2 SEAT SOFA / SOFÁ 2 PLAZAS

High backrest / Respaldo alto
Low backrest / Respaldo bajo



88 35" 210 83" 45 18" 77 30"

3 SEAT SOFA / SOFÁ 3 PLAZAS

High backrest / Respaldo alto
Low backrest / Respaldo bajo



86 34" 90 35" 45 18"

SECTIONAL POUF / PUF MODULAR



90 35" 151 59" 31 12"

COFFEE TABLE / MESA BAJA

42x41x43h / 17"x16"x17"h
90x91x31h / 35"x36"x12"h
90x121x31h / 35"x48"x12"h



59 23" 60 24" 45 18" 63 25" 73 29"

ARMCHAIR / BUTACA



60 24" 61 24" 45 18"

POUF / PUF



96 38" 65 26" 79 31" 92 36"

SERVING CART / CAMARERA



51 20" 44 17" 45 18" 78 35"

DINING CHAIR / SILLA



100 39" 268 106" 74 29"

DINING TABLE / MESA ALTA

100x179x74h / 39"x70"x29"h
100x307x74h / 39"x121"x29"h



40 16" 246 97" 43 17"

BENCH / BANCO

40x161x43h / 16"x63"x17"h
40x281x43h / 16"x111"x17"h

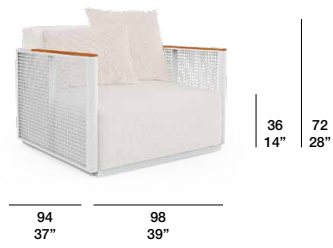

LOUNGE CHAIR / SILLÓN



2 SEAT SOFA / SOFÁ 2 PLAZAS



3 SEAT SOFA / SOFÁ 3 PLAZAS



SECTIONAL 1 / MODULAR 1

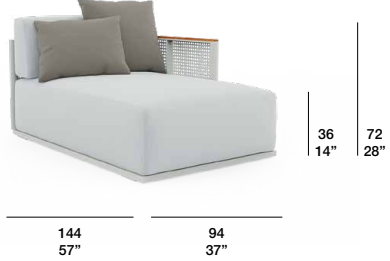

SECTIONAL 2 / MODULAR 2



SECTIONAL 3 / MODULAR 3



SECTIONAL 4 / MODULAR 4



SECTIONAL 5 / MODULAR 5



SECTIONAL 6 / MODULAR 6

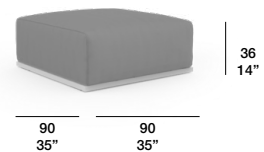

SECTIONAL POUF / PUF MODULAR

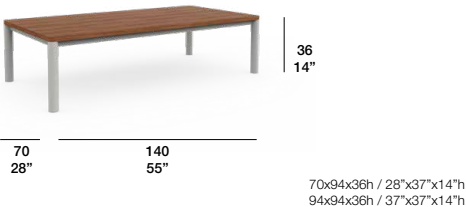

COFFEE TABLE / MESA BAJA

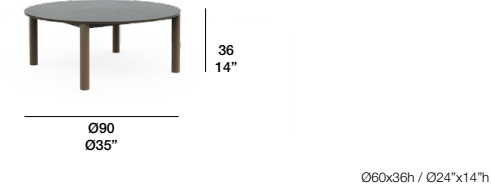

ROUND COFFEE TABLE / MESA BAJA CIRCULAR

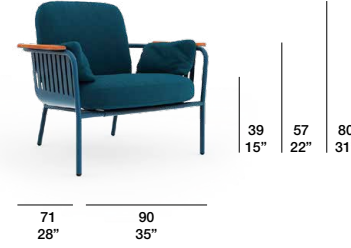

LOUNGE CHAIR / SILLÓN



2 SEAT SOFA / SOFÁ 2 PLAZAS

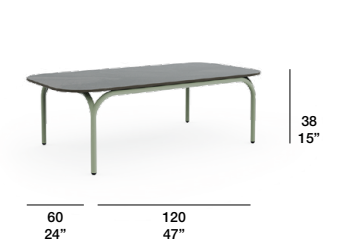

COFFEE TABLE / MESA BAJA

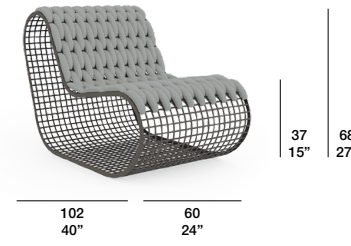

CLUB CHAIR / BUTACA

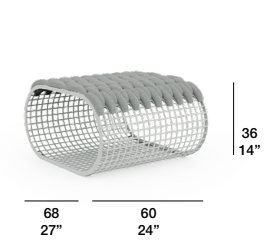
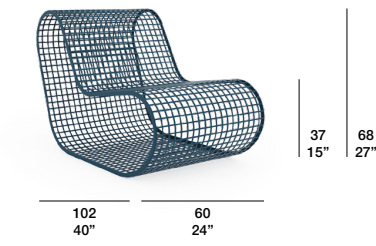

POUF / PUF

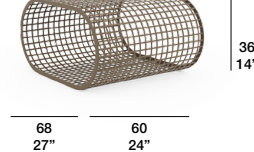

COFFEE TABLE / MESA BAJA



CHAISE LOUNGE / TUMBONA

CHAISE LOUNGE WITH WHEELS / TUMBONA CON RUEDAS

CHAISE LOUNGE ARMS WHEELS / TUMBONA BRAZOS RUEDAS

SECTIONAL 4 / MODULAR 4

SECTIONAL 6 / MODULAR 6

SECTIONAL POUF / PUF MODULAR

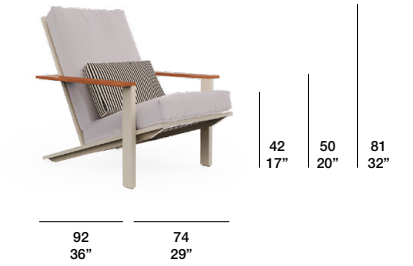
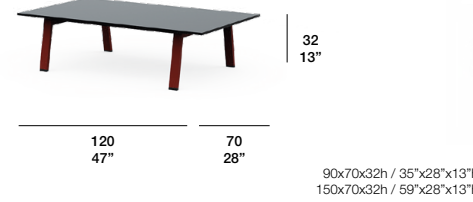

SIDE TABLE / MESA TUMBONA

LOUNGE CHAIR / SILLÓN

COFFEE TABLE / MESA BAJA

RELAX CLUB CHAIR / BUTACA RELAX

RELAX CLUB ARMCHAIR / BUTACA RELAX BRAZOS

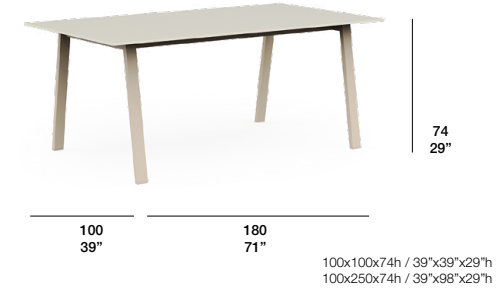
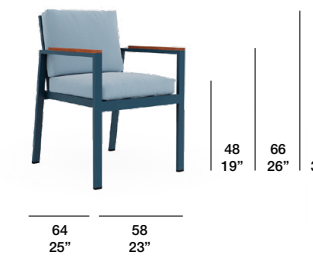
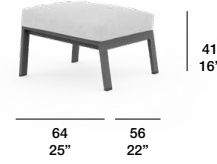
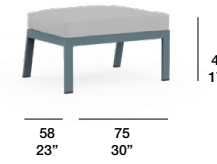
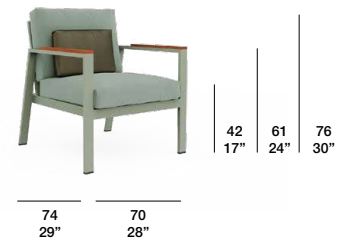

XS LOUNGE CHAIR / SILLÓN XS

POUF / PUF SILLÓN

2 SEAT SOFA / SOFÁ 2 PLAZAS

RELAX POUF / PUF RELAX

DINING ARMCHAIR / SILLA CON BRAZOS

DINING TABLE / MESA ALTA



SECTIONAL 1 / MODULAR 1

SECTIONAL 2 / MODULAR 2

SECTIONAL 3 / MODULAR 3

LOW STOOL / TABURETE BAJO

HIGH STOOL / TABURETE ALTO

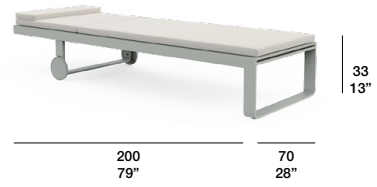

HIGH CHAISE LOUNGE / TUMBONA ALTA

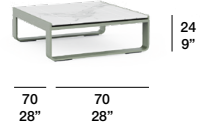

SIDE TABLE / MESA TUMBONA

35x70x24h / 14"x28"x9"h

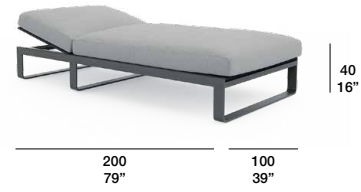

CHILL BED / CAMA CHILL

200x140x40h / 79"x55"x16"h

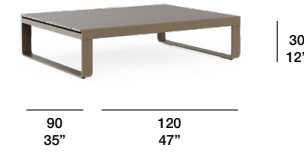

COFFEE TABLE / MESA BAJA

42x42x42h / 17"x17"x17"h
90x90x30h / 35"x35"x12"h



ROUND COFFEE TABLE / MESA BAJA CIRCULAR

Ø42x42h / Ø17"x17"h

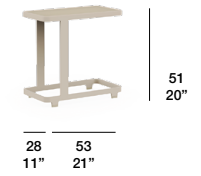

C TABLE / MESA AUXILIAR



ROUND CHILL BED / CAMA CHILL REDONDA

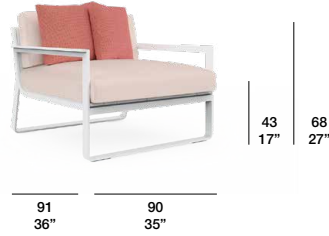

LOUNGE CHAIR / SILLÓN



2 SEAT SOFA / SOFÁ 2 PLAZAS

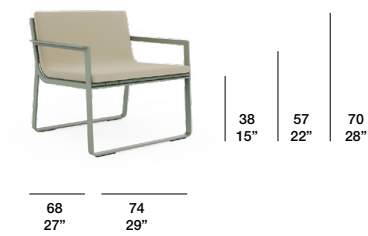

CLUB ARMCHAIR / BUTACA

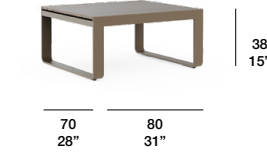

CLUB ARMCHAIR TABLE / MESA BUTACA

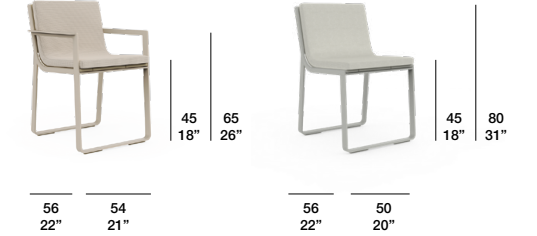

DINING CHAIR / SILLA

Dining armchair / Silla con brazos Dining chair / Silla sin brazos



SECTIONAL 1 / MODULAR 1

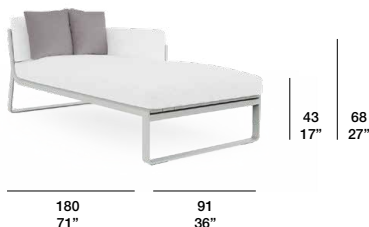

SECTIONAL 2 / MODULAR 2



SECTIONAL 3 / MODULAR 3



ROCKING CHAIR / MECEDORA

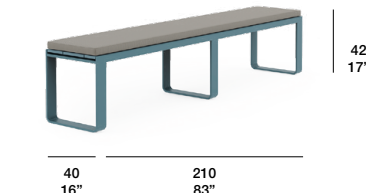

BENCH / BANCO

40x150x42h / 16"x59"x17"h
40x270x42h / 16"x106"x17"h

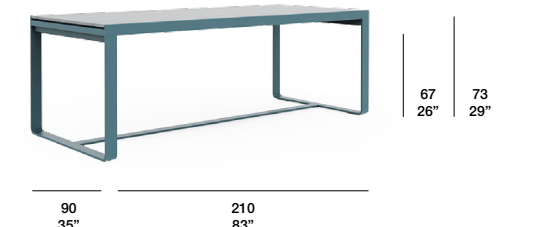

DINING TABLE / MESA ALTA

90x150x73h / 35"x59"x29"h
90x270x73h / 35"x106"x29"h



SECTIONAL 4 / MODULAR 4



SECTIONAL 6 / MODULAR 6



SECTIONAL POUF / PUF MODULAR



ROUND DINING TABLE / MESA ALTA CIRCULAR



SHELVING UNIT / ESTANTERÍA

40x180x73h / 16"x71"x29"h

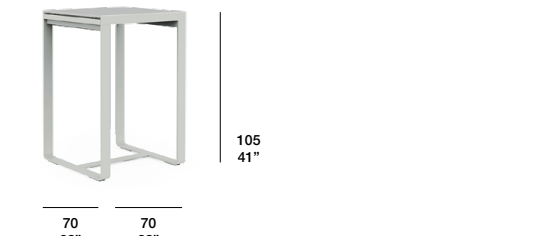

BAR TABLE / MESA BAR

70x180x105h / 28"x71"x41"h

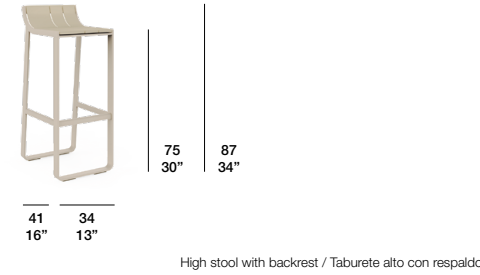
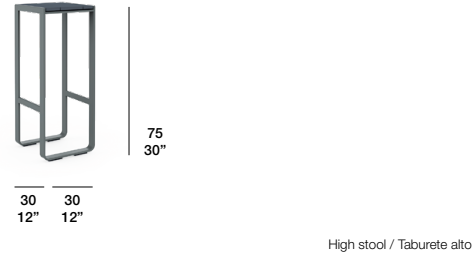
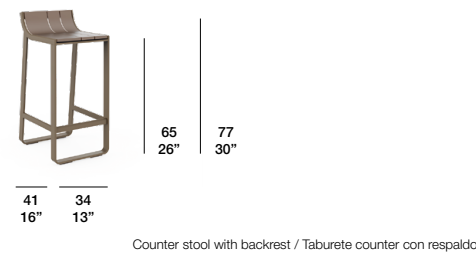

STOOL / TABURETE

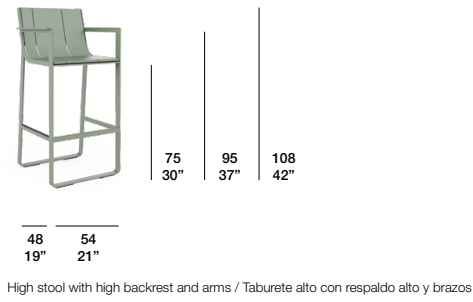
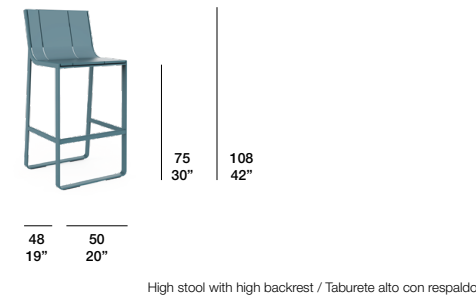

STOOL / TABURETE

FLAT TEXTIL

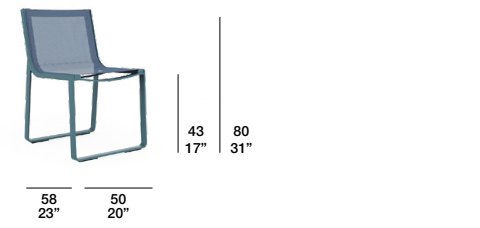
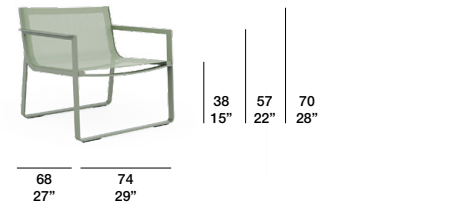
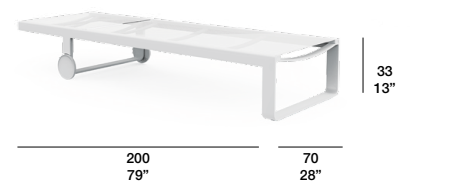

HIGH CHAISE LOUNGE / TUMBONA ALTA

CLUB ARMCHAIR / BUTACA

DINING CHAIR / SILLA

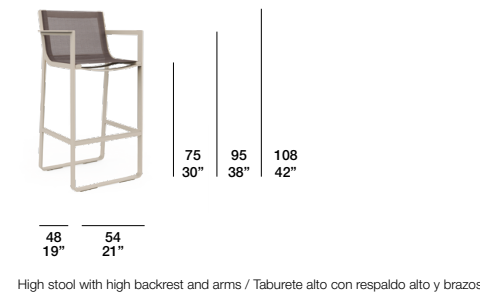
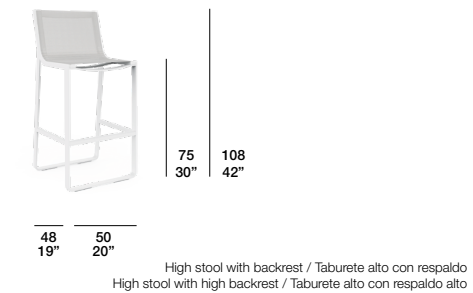
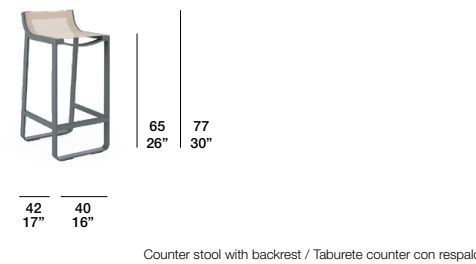

STOOL / TABURETE

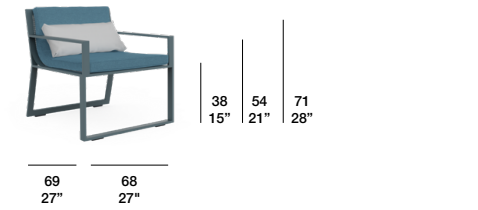

CHAISE LOUNGE / TUMBONA

SIDE TABLE / MESA TUMBONA

CLUB ARMCHAIR / BUTACA CON BRAZOS

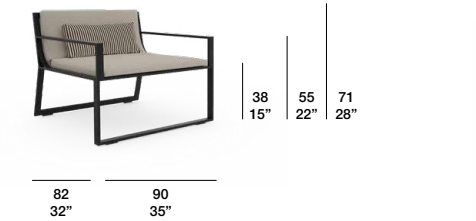
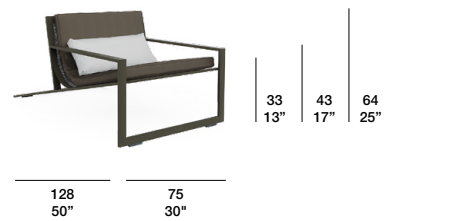

SINGULAR LOUNGE CHAIR / BUTACA SINGULAR

LOUNGE CHAIR / SILLÓN

2 SEAT SOFA / SOFÁ 2 PLAZAS

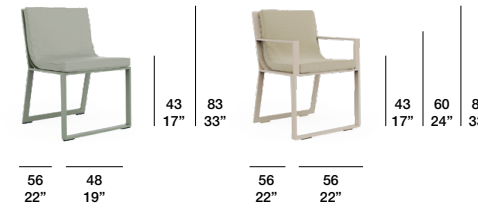
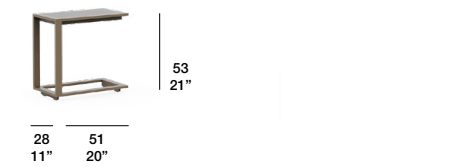
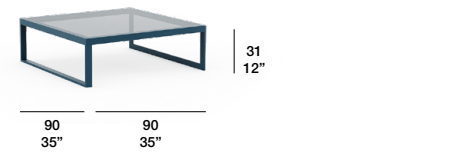

COFFEE TABLE / MESA BAJA

C TABLE / MESA AUXILIAR

DINING CHAIR / SILLA

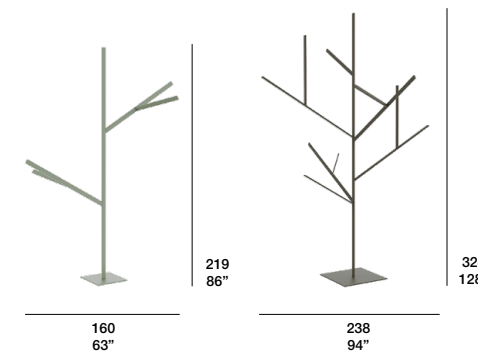
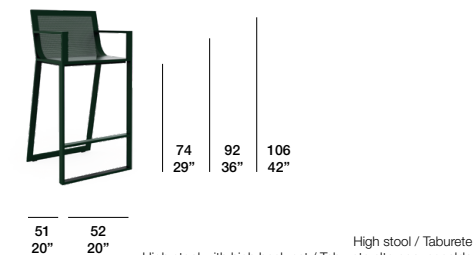
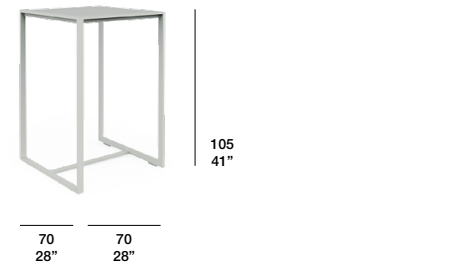

BAR TABLE / MESA BAR

STOOL / TABURETE

TREE LAMP / LÁMPARA ÁRBOL

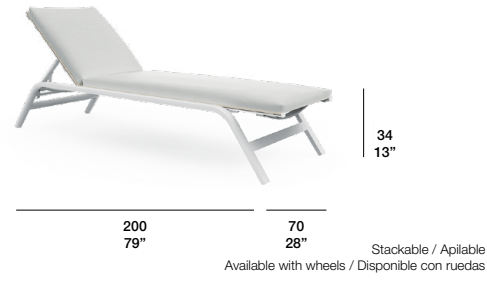

CHAISE LOUNGE / TUMBONA



CHAISE LOUNGE WITH ARMS / TUMBONA CON BRAZOS



SIDE TABLE / MESA TUMBONA



DINING ARMCHAIR / SILLA

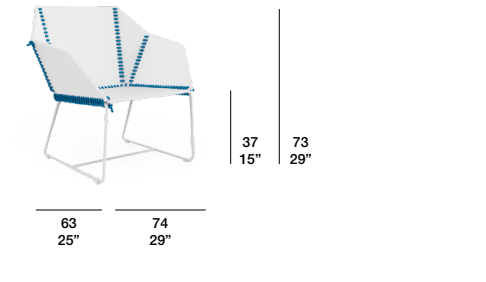

CLUB ARMCHAIR / BUTACA

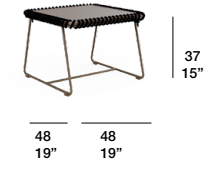

COFFEE TABLE / MESA BAJA

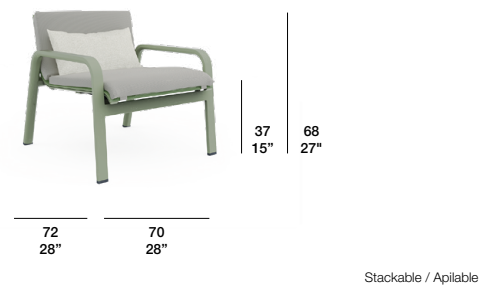

LOUNGE CHAIR / SILLÓN

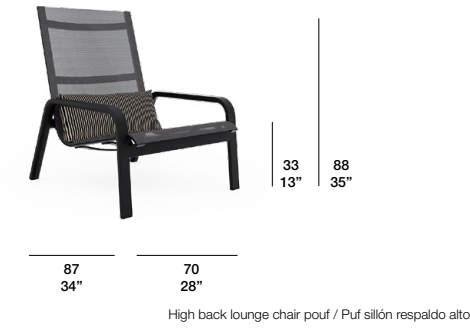

HIGH BACK LOUNGE CHAIR / SILLÓN RESPALDO ALTO

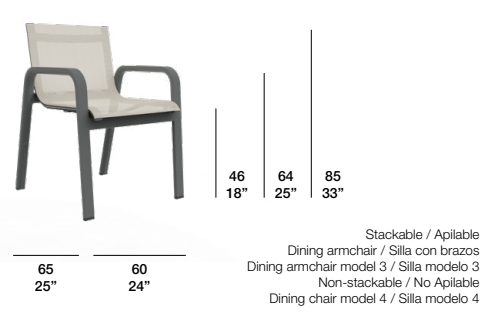

DINING CLUB ARMCHAIR / BUTACA

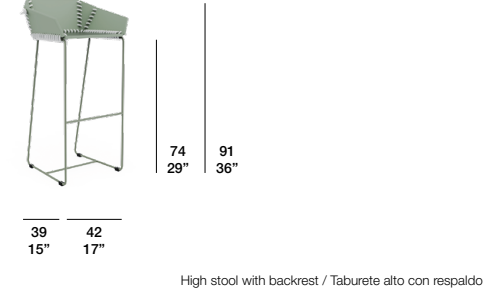

STOOL / TABURETE

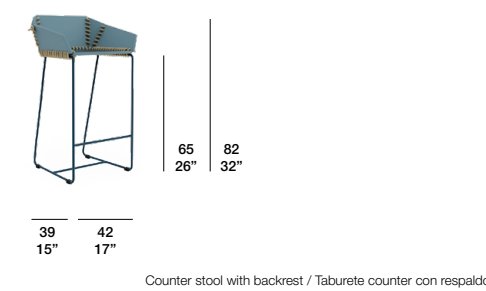

Counter stool with backrest / Taburete counter con respaldo

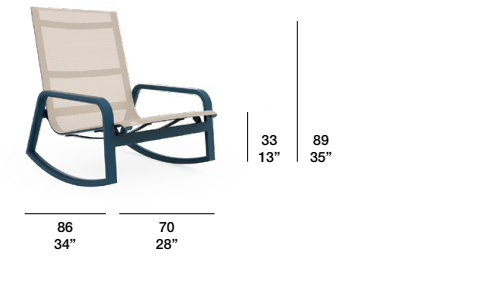

ROCKING CHAIR / MECEDORA



COFFEE TABLE / MESA BAJA

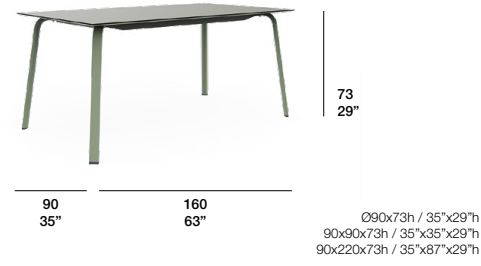

DINING TABLE / MESA ALTA

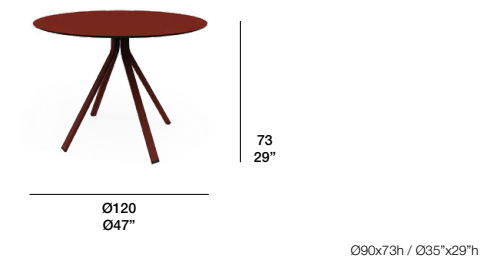

DINING TABLE / MESA MONOPATA



BAR TABLE / MESA BAR

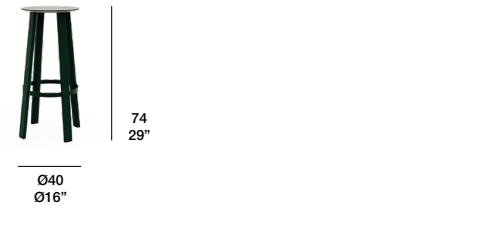

HIGH STOOL / TABURETE ALTO

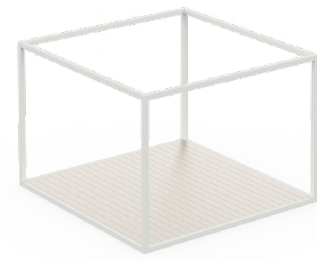

246x246x250h / 97"x97"x98"h
360x360x250h / 142"x142"x98"h
Mod. 1 with/without floor / Mód. 1 con/sin suelo

MODULE 1 FLOOR / MÓDULO 1 SUELO

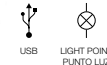
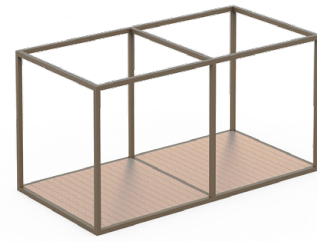

246x484x250h / 97"x191"x98"h
360x712x250h / 142"x280"x98"h
Mod. 2 with/without floor / Mód. 2 con/sin suelo

MODULE 2 FLOOR / MÓDULO 2 SUELO

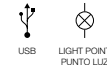

246x484x250h / 97"x191"x98"h
Mod. 6 with/without floor / Mód. 6 con/sin suelo

MODULE 6 FLOOR / MÓDULO 6 SUELO

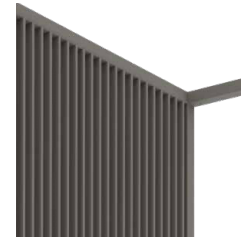

VERTICAL FIXED BLADES TYPE 2 / LAMAS FIJAS VERTICAL TIPO 2



ROLLER / ESTOR



CURTAIN / CORTINA



FIXED BLADES CEILING TYPE 1 / TECHO LAMAS FIJAS TIPO 1

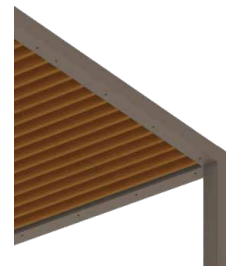

FIXED BLADES CEILING TYPE 2 / TECHO LAMAS FIJAS TIPO 2



FOLDING CEILING / TECHO PLEGABLE



200 140
79" 55"

100x200x24h / 39"x79"x9"h
200x200x24h / 79"x79"x9"h

CHILL BED WITH BACKREST / CAMA CHILL CON RESPALDO



200 200 60 200
79" 79" 24" 79"

Available with curtains / Disponible con cortinas
Available with light / Disponible con luz

CONTRACT DAYBED / DAYBED CONTRACT



200 200 60 200
79" 79" 24" 79"

Available with light / Disponible con luz

DAYBED ELEVATED / DAYBED ELEVADA



MOBILE BLADES CEILING / TECHO LAMAS MÓVILES

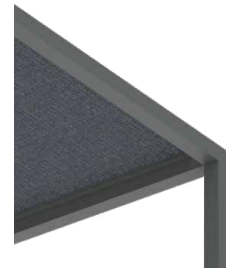

FIXED CANVAS CEILING / TECHO LONA FIJA



LIGHT CEILING / TECHO LIGERO ^{NEW}



200 200 60 200
79" 79" 24" 79"

ELEVATED DAYBED FIXED SLATS / DAYBED ELEVADA LAMAS FIJAS

Available with light / Disponible con luz
Available with curtains / Disponible con cortinas
Elevated daybed fixed slats + sidewall / Daybed elevada lamas fijas + 1 cerramiento



120 200 45 200
47" 79" 18" 79"

TRES AL FRESCO SOFA / SOFÁ TRES AL FRESCO



215 254 45 200
85" 100" 18" 79"

NAO-NAO GARDEN SWING / BALANCÍN NAO-NAO



HORIZONTAL FIXED BLADES TYPE 1 / LAMAS FIJAS HORIZONTAL TIPO 1



HORIZONTAL FIXED BLADES TYPE 2 / LAMAS FIJAS HORIZONTAL TIPO 2



VERTICAL FIXED BLADES TYPE 1 / LAMAS FIJAS VERTICAL TIPO 1



260 260
102" 102"

WIGWAM / TIPI



120 180 43 200
47" 71" 17" 79"

BOOTH / MERENDERO

Available with light / Disponible con luz



320 360 45 250
126" 142" 18" 98"

SOFA PERGOLA / PÉRGOLA SOFÁ

Available with curtains / Disponible con cortinas

ACCESSORIES

R24 ^{NEW} Paula Valentini

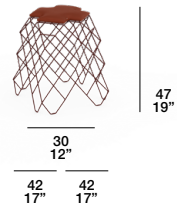

47
19"

30
12"
42
17" 42
17"

LOW STOOL / TABURETE



41
16"

60
24" 60
24"

LOW COFFEE TABLE / MESA BAJA

SAIL Héctor Serrano



120
47"

110
43" 100
39"

POUF / PUF



35
14"

75
30" 75
30"

SQUARE POUF / PUF CUADRADO

GRAPY Kensaku Oshiro



34
13" 70
28"

100
39" 70
28"

GRAPY LOUNGE CHAIR / SILLÓN GRAPY

PICNIC José A. Gandía-Blasco Canales



31
12" 72
28"

100
39" 64
25"

PICNIC DECKCHAIR / HAMACA PICNIC

CLACK! José A. Gandía-Blasco Canales



50
20" 66
26" 87
34"

42
17" 55
22"

CLACK! FOLDING CHAIR / SILLA CLACK!

LA SIESTA Alberto Martínez, Héctor Serrano, Raky Martínez



35
14"

Ø10
Ø4"

JUG / BOTIJO

SAIL Héctor Serrano



120
47"

110
43" 100
39"

POUF / PUF



35
14"

75
30" 75
30"

SQUARE POUF / PUF CUADRADO

ARAM Nendo

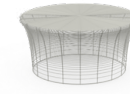

33
13"

Ø71
Ø28"

Low coffee table / Mesa baja



41
16"

Ø61
Ø24"

High coffee table / Mesa alta



25
10"

Ø41
Ø16"

Low stool / Taburete bajo

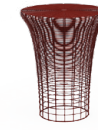

43
17"

Ø36
Ø14"

High stool / Taburete alto

COFFEE TABLE / MESA

STOOL / TABURETE

CELOSÍAS DNA José A. Gandía-Blasco Canales



151
59"

50
20" 150
59"

50x120x171h / 20"x47"x67"h
35x150x111h / 14"x59"x44"h

SCREEN PARTITION WALL / CELOSÍA SCREEN



171
67"

50
20" 120
47"

50x150x151h / 20"x59"x59"h
35x150x111h / 14"x59"x44"h

DNA FAUX WOOD ALUMINIUM / ALUMINIO MADERA



171
67"

50
20" 120
47"

50x150x151h / 20"x59"x59"h
35x150x111h / 14"x59"x44"h

ALUMINIUM PARTITION WALL / CELOSÍA ALUMINIO

FEZ José A. Gandía-Blasco Canales



30
12"

30
12" 30
12"

CANDLE BOX / FAROL



40
16"

40
16" 40
16"

CANDLE BOX / FAROL



50
20"

20
8" 20
8"

CANDLE BOX / FAROL

LLAR Borja García

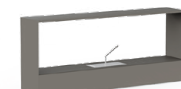

40
16"

20
8" 95
37"

BURNER / QUEMADOR

UMBRA Dirk Wynants



260
102"

295
116"

FOLDING PARASOL / SOMBRILLA

BALI Odosdesign



230
91"

260
102"

FOLDING PARASOL / SOMBRILLA

ENSOMBRA Odosdesign



212
83"

Ø180
Ø71"

FOLDING PARASOL / SOMBRILLA

SAHARA Pablo Gironés



105
41"

Ø60
Ø24"

PLANTER / MACETERO



30
12"

Ø100
Ø39"

PLANTER / MACETERO



43
17"

100
39"

PLANTER / MACETERO



Ø43x43 / Ø17"x17"
Ø80x43 / Ø31"x17"

SONORA Pablo Gironés



40
16"

40
16"

PLANTER / MACETERO



100
39"

40
16" 40
16"

PLANTER / MACETERO

40x100x40 / 16"x39"x16"

SOFT

ATLAS PLAIN

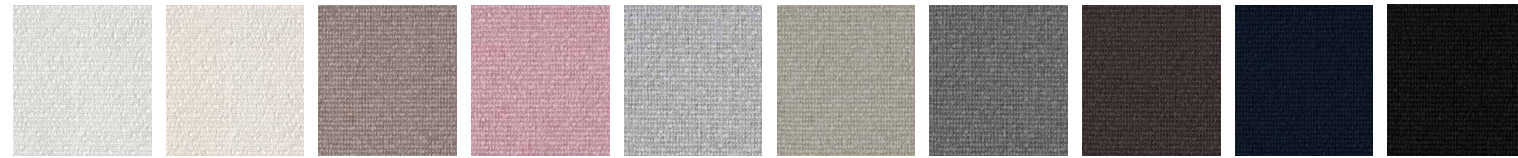

06 07 14 5B 2B 7K 2E 2F 4K 98

DUO



Crudo 07 Plata 80 Beige 04 Piedra 54 Gris claro 51 Naranja 24 Gris oscuro 53

DOLCE

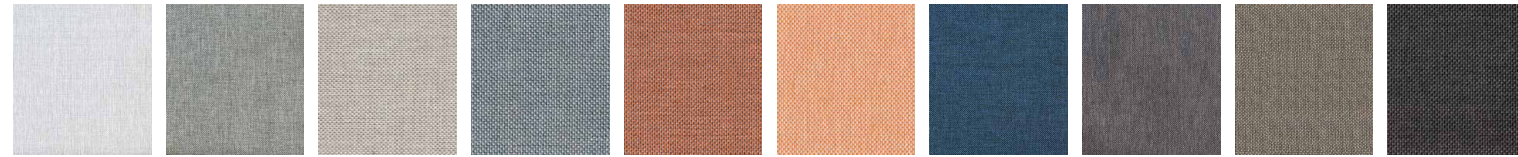

Crudo 07 Gris 51 Piedra 75 Azul grisáceo 45 Naranja 24 Mandarin 29 Azul oscuro 42 Marrón 18 Marrón 09 Gris oscuro 53

AGORA PANAMA



Blanco Garnet

AGORA LISO

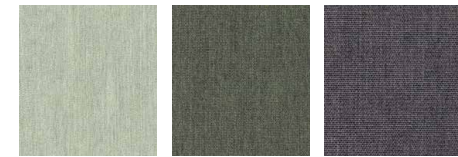

Brote Trebol Grafito

SOLIDS

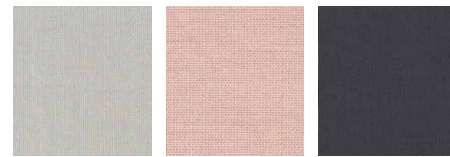

Shingles Blush Carbon

NATTÉ

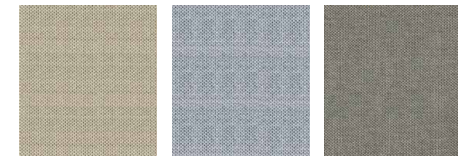

Heather beige Grey chiné Carbon beige

WARM (only cushions)

STRANGE LOVES



Fondo roccioso Cocco bello Sea anchor Carrot stick Eden blu Sale e pepe

NÁUTICA

GEMINI



Blanco Ashgrey Arena Oil Bronce Antracita

SLING



Snowy Sand Taupe Silver

SILVERTEX



Ice Aluminum Plata Sage Sterling Sandstone Lotus Cobre Umber Meteor



Bottle Jet Carbon

WARM

PATIO



Patio 200 Patio 110 Patio 410 Patio 730 Patio 230 Patio 150 Patio 170 Patio 780

BORA-BORA

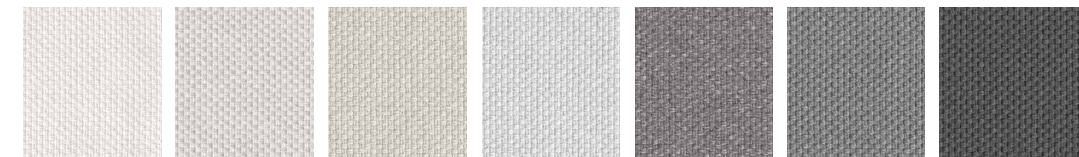

Bora bora 99 Bora bora 08 Bora bora 05 Bora bora 50 Bora bora 54 Bora bora 59 Bora bora 53

WARM (only cushions)

MAJESTIC

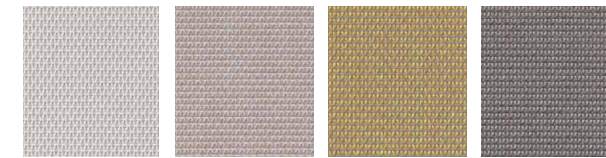

Jager River Citrine Quartz

DOMINO

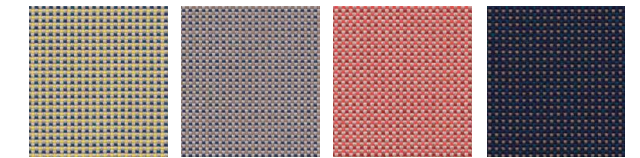

Joker Loto Craps Jackpot

COLORS. COLORES

ALUMINIUM



Anodized 9016 White 7038 Agate grey 1019 Sand Gold ^{NEW} 7006 Bronze 3005 Wine red 7031 Blue grey 5008 Grey blue Night blue ^{NEW}



7033 Cement grey 6007 Bottle green 7043 Anthracite 7039 Quartz grey 9011 Black

STAINLESS STEEL

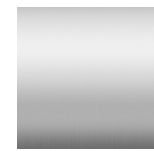

COPPER



TEAK



IROKO



FAUX WOOD ALUMINIUM

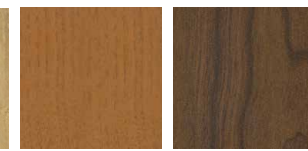

rb001 tk001

MVi ^{NEW}

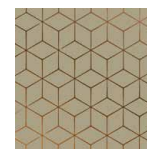

DEKTON

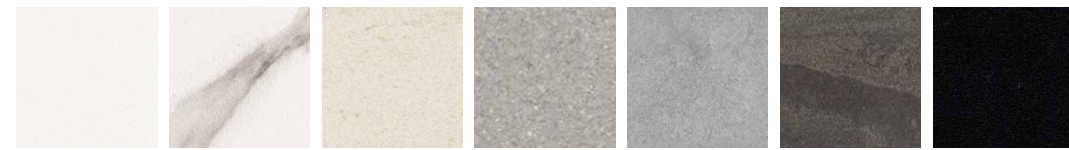

Zenith Aura Danae Sirocco Kreta Radium Domoos

MDi ^{NEW}

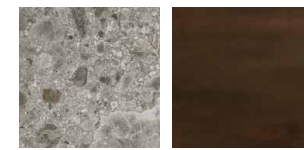

Iseo Korten

PHENOLIC



White Folkestone Possum Sand Bronze Burgundy Lead Anthracite Black

POLYETHYLENE



9016 White 7038 Agate grey 1019 Sand 7033 Cement grey 7006 Bronze 7031 Blue grey 7043 Anthracite

POLYURETHANE



White Agate grey Sand Bronze Blue grey Olive green Anthracite

NOWOOD



White Cement

TAU



White Sand Umber

Material for floor.
Material para el suelo.

FABRICS. TELAS

BATYLINE

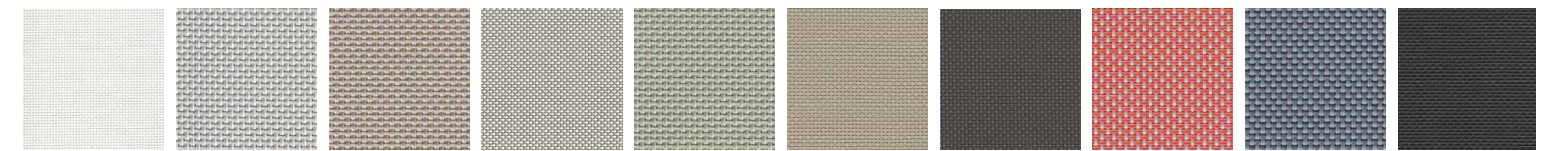

White Grey Stone Camel Green Sand Bronze Terracotta Blue Anthracite

SOLTIS

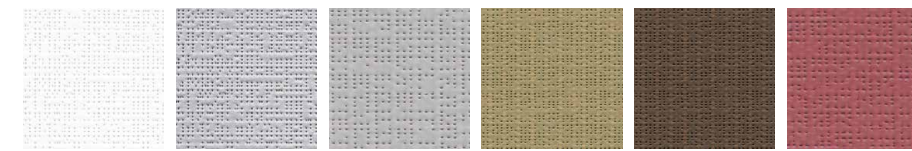

White Silver Light grey Sand Bronze Burgundy

Textile for ceiling and roller blinds.
Tejido para techo y estores.

OPAC



White Light grey Olive Sand Bronze Burgundy Anthracite

PIPING

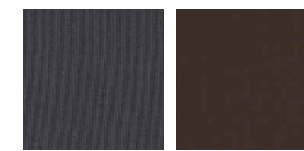

Solids Carbon Agora Liso Café

FABRIC



Grey

WIND



White Mineral

Textile for curtains.
Tejido para cortina.

SOLIDUM

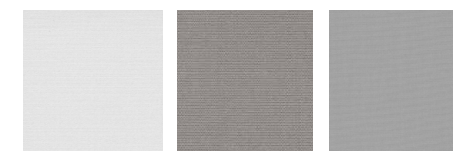

Natural Taupe Grey

Tejido para sombrilla Umbrá.
Textile for Umbrá folding parasol.

ROPE

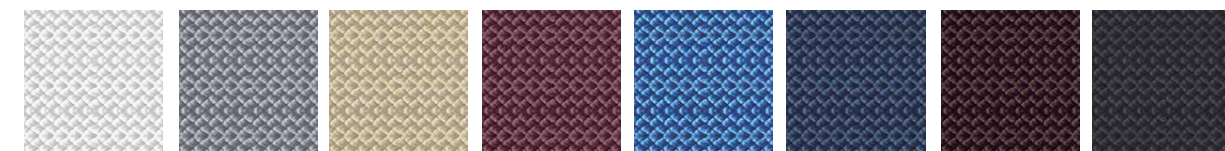

White Grey Sand Burgundy Blue Navy Brown Black

DESIGNERS

Design is an exchange of ideas with which we all learn. We design, edit and work by affinity with national and international architects and creatives with great sensitivity for the environment, our habitat and contemporary design. Among the most recognized are master Kengo Kuma, Patricia Urquiola, Nendo, Todd Bracher, Luca Nichetto, Francesco Meda and David Quincoces, Søren Rose, Mayice, Odosdesign, Fran Silvestre Arquitectos, Mario Ruiz, and José A. Gandía-Blasco Canales, president and creative director of Gandia Blasco Group.

We bet on emerging talent. We discovered the iconic Ensombra designed by Odosdesign in the Nude room of the Habitat Valencia fair 20 years ago and since then it has been one of our classics. We continue to incorporate new designs from emerging talents such as R24 from Estudio Paula Valentini and Textile from Ana Llobet.

El diseño es un intercambio de ideas con las que todos aprendemos. Diseñamos, editamos y trabajamos por afinidad con arquitectos y creativos nacionales e internacionales de una gran sensibilidad por el entorno, el habitat y el diseño contemporáneo. Entre los más reconocidos, el maestro Kengo Kuma, Patricia Urquiola, Nendo, Tod Bracher, Luca Nichetto, Francesco Meda y David Quincoces, Søren Rose, Mayice, Odosdesign, Fran Silvestre Arquitectos, Mario Ruiz, el propio José A. Gandía-Blasco Canales presidente y director creativo de Gandia Blasco Group.

Apostamos por el talento emergente. Descubrimos la iconica Ensombra diseñada por Odosdesign en el salon Nude de la feria Habitat Valencia hace 20 años y desde entonces es uno de nuestros clásicos. Continuamos incorporando mas talentos como R24 del Estudio Paula Valentini y Textile de Ana Llobet.

DESIGNERS

Alejandra Gandía-Blasco
 EN "More than beautiful and well-done things, I am interested in ideas and experiences. The rest is taken for granted. It is a challenge to rethink the objects and the reality that surrounds us with sufficient critical capacity".
 ES "Más que las cosas bonitas y bien hechas me interesan las ideas y las experiencias. Lo demás se da por obvio. Es un reto repensar los objetos y la realidad que nos rodea con la suficiente capacidad crítica".

Diabla
 Valentina Up, Patoso, Calcetín & Plisy.



Ana Llobet
 EN "Textile draws its inspiration from fashion; the concepts and techniques used in textiles have been carried over into the world of furniture".
 ES "Se trata de un proyecto inspirado en la moda, se extrapola al mundo del mobiliario los conceptos y las técnicas empleadas en los textiles".

GANDIABLASCO
 Textile.



Daniel Germani
 EN "There are classics that last thanks to their aesthetic and more if this is combined with functionality and versatility. A good design should always be honest and inspiring".
 ES "Hay clásicos que perduran gracias a su calidad estética, y más si esta se combina con funcionalidad y versatilidad. Un buen diseño siempre debe ser honesto e inspirador".

GANDIABLASCO
 Solanas.



Democràcia Estudio
 EN "Lilly Reich, like so many other women, was forgotten in history. It is time to vindicate those figures and give them the prominence they deserve. Hence the name of the collection, it was designed to cross that paradigm and endure over time".
 ES "Lilly Reich, así como tantas otras mujeres, ha sido olvidada en la historia. Y es momento de reivindicar esas figuras y darles el protagonismo que merecen. De ahí el nombre de la colección, ha sido pensada para atravesar ese paradigma y perdurar con el paso del tiempo".

Diabla
 Lilly.



Borja García
 EN "Our designs are always inspired by sensations, even anecdotes, from our daily lives. Those day-to-day emotions, big and small, constitute the germ of the idea and are later transferred to the product and seek, in turn, to awaken that same feeling in the user".
 ES "Nuestros diseños se inspiran en sensaciones, anécdotas de nuestra vida cotidiana. Son esas pequeñas y grandes emociones del día a día las que constituyen el germen de la idea y las que se trasladan después al producto y despertar ese mismo sentimiento en el usuario".

Diabla
 Trip.
 GANDIABLASCO
 Timeless, Stack, Llar.



Charlotte Lancelot
 EN "When I design, I try to meet the needs of users by observing societal developments. I am attached to the manufacturing process and I like to play with holistic parameters such as a musical score. The design is very different today than when I started. To dare to move the lines, to believe in oneself and the most important: to be concerned about the issues of our time".
 ES "Cuando diseño, intento responder a las necesidades de los usuarios observando la evolución de la sociedad. Sigo muy de cerca el proceso de fabricación y me gusta jugar con parámetros holísticos como una partitura musical. El diseño es muy diferente hoy que cuando empecé. Hay que atreverse a mover las líneas, creer en uno mismo y lo más importante: preocuparse por los temas de nuestro tiempo".

GAN
 Diamond.



Diabla team
 EN "Creativity is our way of life. It is a factor as important in our design strategy as in our business and lifestyle. Therefore, aside from working with designers for our collections, we also design some of our products ourselves. For us is important the originality but also the functionality of the collections that we design, basic furniture of our daily life. Find out more".
 ES "La creatividad es nuestro estilo de vida. Un factor tan importante en nuestra estrategia de diseño como en nuestro estilo empresarial y de vida. Por eso, aparte de contar con diseñadores para nuestras colecciones, nosotros mismos también diseñamos algunos de nuestros productos. Para nosotros es importante la originalidad pero también la funcionalidad de las colecciones que diseñamos, muebles básicos de nuestro día a día".

Diabla
 Mona.



Dirk Wynants
 EN "Designers should have the ambition to change the world for the better", is a believe that is put in daily practice. By offering important added value.
 ES "Los diseñadores deben tener la ambición de cambiar el mundo para mejor." Por ello cada uno de sus diseños tiene que ganarse su razón de ser ofreciendo un importante valor añadido.

GANDIABLASCO
 Umбра.



Emmanuel Gardin
 EN "If an object can fulfill the functions of two, then it satisfies our needs much better and at the same time contributes to reducing consumption, being, consequently, more ecological".
 ES "Si un objeto puede cumplir las funciones de dos, entonces satisface mucho mejor nuestras necesidades y a la vez contribuye a reducir el consumo, resultando, en consecuencia, más ecológico".

Diabla
 Arumi.



Frale Design
 EN "Lena was born from our interest in delving into the smallest details of design, which led us to specialize in furniture and lighting projects, attracted by the world of industrial design".
 ES "Lena nace de nuestro interés por profundizar en los mínimos detalles del diseño, que nos llevó a especializarnos en proyectos de mobiliario e iluminación, atraídas por el mundo del diseño industrial".

Diabla
 Lena.



Héctor Serrano
 EN "I try to create products and projects with which I feel identified in the most human, emotional and extraordinary way possible. Somehow I combine two seemingly opposite concepts: innovation and familiarity".
 ES "Trato de crear productos y proyectos con los que me siento identificado de la manera más humana, emocional y extraordinaria posible. De alguna forma combino dos conceptos aparentemente opuestos: innovación y familiaridad".

Diabla
 Mareta, Sail & Air.
 GANDIABLASCO
 Sail.



José A. Gandía-Blasco Canales
 EN "Beauty has to be functional in any piece of furniture. I like to think of pieces that have been in the collective imagination for a long time, which is why they easily connect with people. Redesigning them brings them closer to the current user".
 ES "La belleza tiene que ser funcional en cualquier mueble. Me atrae pensar en las piezas que llevan mucho tiempo en el imaginario colectivo, por eso conectan fácilmente con la gente. El hecho de haberlas rediseñado las acerca más al usuario actual".

Diabla
 Trip, 356, Lipstick, Clip & Faroles.
 GANDIABLASCO
 Islablanca, DNA, DNA Teak, Timeless, GbModular, Outdoor Spaces & Accessories.



Fran Silvestre
 EN "The BLAU collection aims to evolve the tradition of outdoor furniture connected with architecture and the Mediterranean lifestyle".
 ES "La colección BLAU busca desarrollar la tradición del mobiliario de exterior, vinculándose con la arquitectura y la forma de habitar del Mediterráneo".

GANDIABLASCO
 Blau.



Francesco Meda & David Quincoces
 EN "We set ourselves the goal to give shape to what GANDIABLASCO means today: this is done through a design that dives into the sensations related to life inside the house but applied to the enjoyment of outdoor spaces".
 ES "Nos hemos propuesto materializar lo que GANDIABLASCO es hoy, con un diseño que explora las sensaciones asociadas a la vida dentro de casa trasladadas al disfrute de los espacios al aire libre".

GANDIABLASCO
 Onsen.



Kensaku Oshiro
 EN "I try to understand the fundamental values of the culture and environment in question and highlighting them".
 ES "Intento comprender los valores fundamentales de la cultura y el entorno en cuestión y destacarlos. Veo cada proyecto como un reto único que debe resolverse en sus propios términos".

GAN
 Grapy.
 GANDIABLASCO
 Grapy.



Luca Nichetto
 EN "To me, a "good design" is something that should match the characteristics of the partner you're collaborating with as well as meet the user's expectations of the product. If you're able to achieve these two apparently simple things, that means you've successfully created a good design".
 ES "Para mí, un "buen diseño" es algo que cumple dos requisitos: que coincide con las características de los colaboradores con los que estás trabajando y que cumple con las expectativas del usuario. Si eres capaz de conseguir estos dos objetivos aparentemente sencillos, entonces puedes decir que has creado un buen diseño".

GANDIABLASCO
 Onde.



Made Studio

EN "I have always enjoyed asking myself how and why things are done. What started out as a concern, little by little turned into a passion and finally became a profession".
ES "Siempre me ha gustado preguntarme cómo y por qué se hacen las cosas. Lo que empezó siendo una inquietud, poco a poco se transformó en una pasión convirtiéndose finalmente en una profesión".

Diabla
Arp & Vent.
GANDIABLASCO
Bosc.



Manel Jiménez Ibáñez & Violeta Alcaide Weishaupt

EN "Touffu is an architectural exercise based on the screwless assembly of traditional Japanese carpentry. Because our pets also have the right to live in a stylish environment".
ES "Touffu es un ejercicio arquitectónico basado en el ensamblaje sin tornillería de la carpintería tradicional japonesa. Por que nuestros animales domésticos también tienen derecho a vivir en un entorno con estilo".

Diabla
Touffu.



Mut Design

EN "Our designs are always inspired by sensations, even anecdotes, from our daily lives. Those day-to-day emotions, big and small, constitute the germ of the idea and are later transferred to the product or the final project and seek, in turn, to awaken that same feeling in the user or viewer".
ES "Nuestros diseños siempre se inspiran en sensaciones, en anécdotas, incluso, de nuestra vida cotidiana. Son esas pequeñas y grandes emociones del día a día las que constituyen el germen de la idea y las que se trasladan después al producto o al proyecto final y que buscan, a su vez, despertar ese mismo sentimiento en el usuario o espectador".

Diabla
Grill.



Nendo

EN "My inspiration comes from daily life: the day to day can be so rewarding if one pays the attention it deserves." "The open gaps between the wires gradually increase creating a sensation of gradation. A design created thanks to a small change applied to an existing technique".
ES "Mi motivo de inspiración es la vida cotidiana: el día a día puede convertirse en algo más si le prestas la atención que se merece." "Los espacios que quedan entre los alambres se amplían gradualmente, creando una sensación de gradación. Un diseño creado gracias a un pequeño cambio aplicado a una técnica ya existente".

GANDIABLASCO
Aram.



Mario Ruiz

EN "Renowned for its visual lightness, its design and comfort FLAT is also a very flexible collection when it comes to combining elements to creating a space based on its modular range of options".
ES "Reconocida por su ligereza visual, su equilibrio y su confort, FLAT también destaca por su flexibilidad, a la hora de crear espacios, dada la variedad de piezas modulares incluidas en la colección".

GANDIABLASCO
Flat & Flat Textil.



Mayice Studio

EN "BUIIT –which means void in Valencian–, starts from an aluminium mesh curved to form sinuous elements of sculptural appearance".
ES "BUIIT –que significa vacío en valenciano–, parte de una malla de aluminio curvada hasta formar sinuosos elementos de escultórica presencia".

GANDIABLASCO
Buit.



OdosDesign

EN "Our work is based on a common search for new basics and on the combination of functionality, creativity, and aesthetics, as they aim to offer optional design solutions to their clients. We believe in strong ideas and passionate work, whatever the scale of the product or the location. We find creativity enriching in all its forms".
ES "Nuestro trabajo parte de un denominador común, el de la búsqueda de nuevos hábitos y de la unión entre funcionalidad, creatividad y estética, con el fin de aportar las mejores soluciones de diseño a nuestros clientes. Creemos en ideas fuertes y en el trabajo realizado con pasión, sea cual sea la escala del producto y su ubicación. La creatividad nos parece enriquecedora en cualquier tipo de sus vertientes".

Diabla
Cacao.
GANDIABLASCO
Bali & Ensombra.



Oiko Design

EN "As a studio, we work through materials in a very material-based design process. Sometimes we make them speak and express an aesthetic and a story in a very evident way, but also in other cases we try to silence the material and simply make it work. This is the case with Plier chair. That visually it doesn't express but that you feel when you use it".
ES "Como estudio, trabajamos a través de los materiales en un proceso de diseño muy basado en la materia. A veces les hacemos hablar y expresar una estética y una historia de una manera muy evidente, pero también en otros casos tratamos de silenciar al material y simplemente hacerlo funcionar. Es el caso de la silla Plier. Que visualmente no exprese pero que se sienta al usarse".

Diabla
Plier.



Pablo Gironés

EN "There are good talent pools in Europe, and I think the level is improving more and more. Having a good cultural base is essential. So is knowing the work of the great industrial and graphic designers of the 20th century. It has served me a lot".

ES "Hay buenas canteras de talento en Europa, y creo que el nivel mejora cada vez más. Tener una buena base cultural es imprescindible. También lo es conocer el trabajo de los grandes diseñadores industriales y gráficos del siglo XX. A mí me ha servido mucho".

Diabla

356 & Gobi.

GANDIABLASCO

Sahara & Sonora.



Patricia Urquiola

EN "Design is based on an idea, a need and a briefing and is transformed into a tool for it is reproducible, with a predetermined duration in time and with a series of values not only functional, ergonomic.. not only of physical comfort but also of mental and emotional comfort".

ES "El diseño se basa en una idea, una necesidad y un briefing y se transforma en una herramienta para vivir, reproducible, con una duración predeterminada en el tiempo y con una serie de valores no solo funcionales, ergonómicos... no solo de confort físico sino también mental y emocional".

Gan

Garden Layers.



Rocío Gambín

EN "I like to keep things simple and honest, to stay with the essentials and to be understood. In a chair design to be as encapsulated as possible, any extra features are superfluous".

ES "Me gusta que las cosas sean sencillas y honestas, quedarme con lo esencial y que se entienda. En una silla lo más sintetizada posible, cualquier rasgo extra sobra".

Diabla
Easy.



Romero & Vallejo

EN "For us, the different creative disciplines have a lot in common with each other. We enjoy working across the board, creating environments that reflect a lifestyle. Between architecture and product design there is a difference mainly in scale".

ES "Para nosotros, las diferentes disciplinas creativas tienen mucho en común las unas con las otras. Disfrutamos trabajando transversalmente, creando entornos que reflejan un estilo de vida. Entre la arquitectura y el diseño de producto hay una diferencia de escala principalmente".

Diabla
Ploid.



Paula Valentini

EN "Weightlessness, suspension and the ethereality against the resistance of matter are axes that organize her research within the framework of the relationships between art, design, architecture, city and nature".

ES "La ingravidez, la suspensión y lo etéreo en oposición a la resistencia de la materia son ejes que organizan sus investigaciones en el marco de las relaciones entre arte, diseño, arquitectura, ciudad y naturaleza".

GANDIABLASCO

R24.



Raky Martínez, Alberto Martínez & Héctor Serrano

EN "We were interested in designing an object that would combine the traditional jug, used to keep water cool, with the shape of a plastic bottle. It's a humorous review of a very iconic cultural element for us".

ES "Nos interesaba diseñar un objeto que combinara el sistema tradicional de un botijo para mantener fresca el agua con la forma de una botella de plástico. Es una revisión en clave de humor de un elemento culturalmente muy icónico para nosotros".

Diabla

La Siesta.

GANDIABLASCO

La Siesta.



Samuel Wilkinson

EN "A deep understanding of materials and manufacturing helps to overcome limitations and, at the same time, achieve a high level of detail and craftsmanship. TUBA may look very simple, but its clean aesthetic is the result of a highly technical process".

ES "Un profundo conocimiento de los materiales y la fabricación ayudan a superar las limitaciones y, al mismo tiempo, a conseguir un alto nivel de detalle y artesanía. TUBA puede parecer muy simple, pero su estética limpia es el resultado de un proceso altamente técnico".

Diabla

Tuba.



Sebastian Herkner

EN "The outdoors is like a new indoors and I think ISLA can be placed both indoor and outdoor and still do its job: it gives you comfort, sense of safety and it is the perfect place for communication. It is a welcoming outdoor haven".

ES "El exterior es un nuevo interior y creo que ISLA puede colocarse tanto en uno como en el otro: es sinónimo de comodidad, seguridad y es el lugar perfecto para la comunicación. Es un acogedor refugio al aire libre".

GANDIABLASCO

Isla.



Søren Rose

EN "Everything is reduced to quality and details. Taking care of these two factors to the extreme allows us to achieve pieces that we want to live with, that last and acquire meaning over time".

ES "Todo se reduce a la calidad y a los detalles. Cuidar al extremo estos dos factores permite lograr piezas con las que queremos convivir, que perduran y adquieren significado con el paso del tiempo".

GANDIABLASCO

Capa.



Teresa Sapey + Partners

EN "I think that interior and exterior design are coming increasingly interlinked, especially in countries with hotter Mediterranean climates – When developing Costuras we wanted to create a versatile product for both the interior and the exterior, for children and adults, for homes and hotels and restaurants".

ES "Creo que cada vez más el interior y el exterior se van fusionando, sobre todo en los países más cálidos y mediterráneos – Al desarrollar Costuras hemos querido crear un producto versátil tanto para interior como para exterior, para niños como para adultos, para casas como para hoteles y restaurantes".

Diabla

Costuras.



Todd Bracher

EN "MASS tries to address a real need from authenticity and to put furniture design at the forefront of the user experience, and that need is to foster interaction and interconnection in a scalable and flexible way".

ES "MASS intenta abordar una necesidad real desde la autenticidad y poniendo el diseño de mobiliario al servicio de la experiencia del usuario: y esa necesidad es la de fomentar la interacción y la interconexión de forma escalable y flexible".

GANDIABLASCO

Mass.



Yolanda Herraiz

EN "Daily ways on do things can drive people onto a non suggestion experiences and with that, do things same way day by day but. try to add a new action, for sure you will notice unexpected changes happen".

ES "Las formas diarias de hacer las cosas pueden llevar a las personas a experiencias sin sugerencias y, con eso, hacer las cosas de la misma manera día a día, pero intente agregar una nueva acción, seguramente notará cambios inesperados".

GANDIABLASCO

Nao-Nao.



GANDIABLASCO

gandiablasco.com

Creative Director
& Project Manager

José A.

Gandía-Blasco

Canales

Art Direction

Gandiablasco

studio & Odosdesign

Photographers

Gandiablasco,

Ángel Segura, Luis

Beltrán, Visualizers

& Quatre Caps

Copy

Tachy Mora

Special thanks

LZF

Editorial concept

P.A.R

Graphic design

P.A.R

Translations

Staphaus

Printed in Spain, 2022

by Agpograf



Gandia Blasco Group

GANDIA BLASCO S.A.
Músico Vert 4, 46870 Ontinyent,
Valencia, Spain
T. +34 96 291 13 20
info@gandiablasco.com

GANDIA BLASCO USA Inc.
52 Greene St.
New York, NY 10013
T. +1 212 421 6701
info-usa@gandiablasco.com